



Installation Guide

# Three Phase Inverter with SetApp Configuration

Model Name: SExxxK for Australia

Version 1.1

# Disclaimers

## Important Notice

Copyright © SolarEdge Inc. All rights reserved.

No part of this document may be reproduced, stored in a retrieval system or transmitted, in any form or by any means, electronic, mechanical, photographic, magnetic or otherwise, without the prior written permission of SolarEdge Inc.

All company and brand products and service names are trademarks or registered trademarks of their respective holders.

Patent marking notice: see

The general terms and conditions of delivery of SolarEdge shall apply.

The content of these documents is continually reviewed and amended, where necessary. However, discrepancies cannot be excluded. No guarantee is made for the completeness of these documents.

The images contained in this document are for illustrative purposes only and may vary depending on product models.

## Emission Compliance

This equipment has been tested and found to comply with the limits applied by the local regulations.

These limits are designed to provide reasonable protection against harmful interference. This equipment generates, uses and can radiate radio frequency energy and, if not installed and used in accordance with the instructions, may cause harmful interference to radio communications. However, there is no guarantee that interference will not occur in a particular installation. If this equipment does cause harmful interference to radio or television reception, which can be determined by turning the equipment off and on, you are encouraged to try to correct the interference by one or more of the following measures:

- Reorient or relocate the receiving antenna.
- Increase the separation between the equipment and the receiver.
- Connect the equipment into an outlet on a circuit different from that to which the receiver is connected.
- Consult the dealer or an experienced radio/TV technician for help.

Changes or modifications not expressly approved by the party responsible for compliance may void the user's authority to operate the equipment.

## Safety Warnings

Please review the following safety guidelines, and observe them when handling the equipment.

- Always power down the inverter before opening the unit. Perform the following steps:
  - Switch the inverter's ON/OFF switch to OFF, and wait five minutes for the capacitors to discharge
  - Cut off AC power to the inverter by turning off the circuit breakers on the distribution panel.
  - Turn the DC Safety Unit's switch (if applicable) to OFF.

# Revision History

## Version 1.1 (Oct. 2021)

Initial release

## Contents

---

<b>Disclaimers</b> .....	<b>1</b>
Important Notice .....	1
Emission Compliance .....	2
Safety Warnings .....	2
<b>Revision History</b> .....	<b>3</b>
<b>HANDLING AND SAFETY INSTRUCTIONS</b> .....	<b>6</b>
Safety Symbols Information .....	6
<b>Chapter 1: Introducing the SolarEdge Power Harvesting System</b> .....	<b>9</b>
Power Optimiser .....	9
Inverter .....	9
Designer .....	10
Monitoring Platform .....	10
SetApp .....	10
Installation Procedures .....	10
Installation Equipment List .....	10
<b>Chapter 2: Installing the Power Optimisers</b> .....	<b>12</b>
Safety .....	12
Installation Guidelines .....	13
Step 1: Mounting the Power Optimisers .....	16
Step 2: Connecting a PV module to a Power Optimiser .....	16
Step 3: Connecting Power Optimisers in PV strings .....	17
Step 4: Verifying Proper Power Optimiser Connection .....	18
Step 5: Connecting the Strings to a Combiner Box .....	19
<b>Chapter 3: Installing the Inverter</b> .....	<b>20</b>
Package Contents .....	20
Identifying the Inverter .....	20
Inverter Interfaces .....	20
Mounting the Inverter .....	25
<b>Chapter 4: Connecting Grid and PV Strings to the Inverter</b> .....	<b>30</b>
Grid Connection Guidelines .....	30
Connecting to the AC Grid .....	31
Connecting the AC Grid to the Inverter .....	31
Connecting the PV Array to the Inverter .....	33
<b>Chapter 5: Setting Up Communication with the Monitoring Platform</b> .....	<b>37</b>
Communication Options .....	37
Communication Connectors .....	39
Removing the Inverter Cover .....	40
Removing the DC Safety Unit Cover .....	40
Creating an Ethernet (LAN) Connection .....	40

---

Creating an RS485 Bus Connection .....	44
RS485 Bus Configuration .....	46
Verifying the Connection .....	47
<b>Chapter 6: Activating, Commissioning and Configuring the System .....</b>	<b>48</b>
Step 1: Activating the Installation .....	48
Step 2: Commissioning and Configuring the Installation .....	49
Step 3: Verifying Proper Activation and Commissioning .....	51
Reporting and Monitoring Installation Data .....	51
Signaling Options .....	53
<b>Appendix A: Errors and Troubleshooting .....</b>	<b>55</b>
Identifying Errors .....	55
Troubleshooting Communication .....	56
Power Optimiser Troubleshooting .....	57
<b>Appendix B: Adding Optional Components .....</b>	<b>59</b>
AC Surge Protection Device (SPD) .....	59
DC Surge Protection Device (SPD) .....	59
<b>Appendix C: Mechanical Specifications .....</b>	<b>60</b>
Dimensions of Inverter Mounting Bracket .....	61
<b>Support Contact Information .....</b>	<b>62</b>

# HANDLING AND SAFETY INSTRUCTIONS

## Safety Symbols Information

The following safety symbols are used in this document. Familiarize yourself with the symbols and their meaning before installing or operating the system.

### WARNING!



Denotes a hazard. It calls attention to a procedure that, if not correctly performed or adhered to, could result in **injury or loss of life**. Do not proceed beyond a warning note until the indicated conditions are fully understood and met.

### CAUTION!



Denotes a hazard. It calls attention to a procedure that, if not correctly performed or adhered to, could result in **damage or destruction of the product**. Do not proceed beyond a caution sign until the indicated conditions are fully understood and met.



### NOTE

Denotes additional information about the current subject.



### IMPORTANT SAFETY FEATURE

Denotes information about safety issues.



### Warning!

To reduce the risk of injury, read all instructions in this document.

### WARNING!



When servicing or replacing SolarEdge equipment, instructions in the SolarEdge Inverter Installation Guide must be followed to maintain the integrity of the PV hazard control system. SolarEdge Power Optimizers and/or inverters may only be replaced with SolarEdge Power Optimizers and/or inverters. Third party equipment is not compatible with SolarEdge equipment.



### WARNING!

Using this equipment in a manner not specified by SolarEdge in this document may impair the protection provided by this equipment.



### WARNING!

The inverter cover must be opened only after switching the inverter ON/OFF/P switch located at the bottom of the inverter to OFF. This disables the DC voltage inside the inverter. Wait five minutes before opening the cover. Otherwise, there is a risk of electric shock from energy stored in the capacitors.



P = Program/Pair  
1 = ON  
0 = OFF

**WARNING!**

Before operating the inverter, ensure that the inverter grounded properly. This product must be connected to a grounded, metal, permanent wiring system, or an equipment-grounding conductor must be run with the circuit conductors and connected to the equipment grounding terminal or lead on the product.

**WARNING!**

Opening the inverter and repairing or testing under power must be performed only by qualified service personnel familiar with this inverter.

**WARNING!**

SafeDC complies with IEC60947-3 when installing the system with a worst case SafeDC voltage (under fault conditions) < 120V.



The worst case voltage is defined as:  $V_{oc, max} + (PV \text{ string Length} - 1) * 1V$ , where:

- $V_{oc, max}$  = Maximum  $V_{oc}$  (at lowest temperature) of the PV modules in the PV string (for a PV string with multiple modules, use the max value)
- PV string Length = number of Power Optimisers in the PV string

**CAUTION!**

This unit must be operated according to the technical specification datasheet provided with the unit.

**CAUTION!**

**HEAVY OBJECT.** To avoid muscle strain or back injury, use proper lifting techniques, and if required - a lifting aid.

**NOTE**

The symbol  appears at grounding points on the SolarEdge equipment. This symbol is also used in this manual.

**NOTE**

SolarEdge inverters can be installed in sites with an alternative power source such as a generator. SolarEdge requires installing a physical or electronic interlock, which will signal to the inverter when the grid has been disconnected. Interlock procurement, installation, maintenance and support are the responsibility of the installer. Damage to the inverter due to incorrect interlock installation or use of an interlock that is incompatible with the SolarEdge system will render the SolarEdge warranty invalid.



For more information on connecting an alternative power source to SolarEdge inverter, refer to

<https://www.solaredge.com/sites/default/files/se-inverter-support-of-voltage-sources.pdf>.



# Chapter 1: Introducing the SolarEdge Power Harvesting System

The SolarEdge power harvesting solution maximizes the power output from any type of solar photovoltaic (PV) installation while reducing the average cost per watt. The following sections describe each of the system's components.

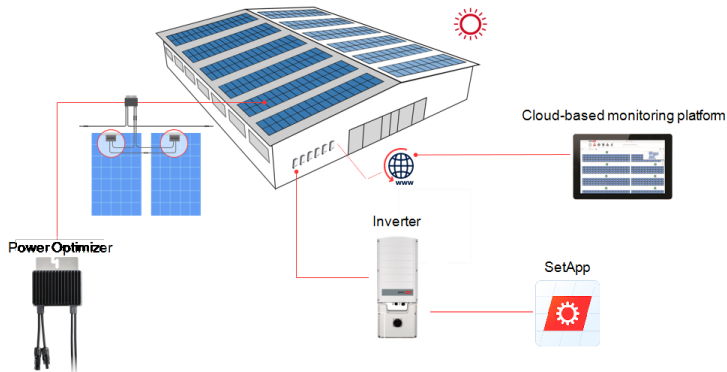

Figure 1: The SolarEdge power – harvesting system components

## Power Optimiser

The Power Optimisers are DC-DC converters connected to PV modules in order to maximize power harvesting by performing independent Maximum Power Point Tracking (MPPT) at the module level.

Each Power Optimiser also transmits module performance data over the DC power line to the inverter.

## Inverter

An external The inverter efficiently converts DC power from the modules into AC power that can be fed into the main AC service of the site and from there to the grid. The inverter also receives the monitoring data from each power optimizer and transmits it to a central server (the monitoring platform; requires Internet connection).

An external Connection Unit has a manually operated switch for disconnecting the DC power of a SolarEdge system. The Connection Unit is located below the inverter and is connected to the inverter with AC and DC wires.

## Designer

Designer recommends inverter and Power Optimiser selection per site size and enables report generation. You can create a project in Designer and export the site design with the PV array layout to the monitoring platform.

## Monitoring Platform

The monitoring platform enables monitoring the technical and financial performance of one or more SolarEdge sites. It provides past and present information on the system performance both at the system and module levels.

## SetApp

SetApp is a mobile application that enables activating and configuring the inverter through a smartphone or any mobile device.

## Installation Procedures

The following procedures are used for installing and setting up a new SolarEdge site. Some procedures, may also apply to modify an existing site.

1. [Connecting Power Optimizers in Strings](#), page 1
2. [Recording power optimiser serial numbers \(optional\)](#), page 52
3. [Mounting the inverter](#), page 25
4. [Activating, commissioning and configuring the system](#), page 48
5. [Connecting the inverter to the monitoring platform](#), page 53

## Installation Equipment List

Standard tools can be used during the installation of the SolarEdge system. The following is a recommendation of the equipment needed for installation:

- 4 mm Allen torque screwdriver for the inverter enclosure screws
- Standard torque flat-head screwdrivers set
- Non-contact voltage detector
- Mounting hardware (stainless bolts, nuts, and washers) for attaching:
  - the mounting brackets to the mounting surface
  - the power optimiser to the racking (not required for smart modules)
- Tools:

- Wire cutters
- Wire strippers
- Voltmeter
- Mobile phone with latest SetApp version

For installing the communication options, you may also need the following:

- For Ethernet:
  - CAT6 twisted pair Ethernet cable with RJ45 connector
  - If using a CAT6 cable spool: RJ45 plug and RJ45 crimper
- For RS485 :
  - Four- or six-wire shielded twisted pair cable
  - Watchmaker precision screwdriver set

## Chapter 2: Installing the Power Optimisers

### Safety

#### WARNING!

-  When modifying an existing installation, turn OFF the inverter ON/OFF/P switch, the DC Disconnect Switch DC Safety Unit ON/OFF switch and the AC circuit breaker on the main AC distribution panel.

#### CAUTION!

-  Power Optimisers are IP68/NEMA6P rated. Choose a mounting location where optimisers will not be submerged in water.

#### CAUTION!

-  This unit must be operated according to the operating specifications provided with the unit.

#### CAUTION!

-  Cutting the Power Optimiser input or output cable connector is prohibited and will void the warranty.

#### CAUTION!

-  All PV modules must be connected to a Power Optimiser.

#### CAUTION!

-  If you intend to mount the Power Optimisers directly to the module or module frame, first consult the module manufacturer for guidance regarding the mounting location and the impact, if any, on module warranty. Drilling holes in the module frame should be done according to the module manufacturer instructions.

#### IMPORTANT SAFETY FEATURE

-  Modules with SolarEdge Power Optimisers are safe. They carry only a low safety voltage before the inverter is turned ON. As long as the Power Optimisers are not connected to the inverter or the inverter is turned OFF, each Power Optimiser will output a safe voltage of 1V.

**CAUTION!**

Installing a SolarEdge system without ensuring compatibility of the module connectors with the Power Optimiser connectors may be unsafe and could cause functionality problems such as ground faults, resulting in inverter shut down. To ensure mechanical compatibility of the SolarEdge Power Optimisers' connectors with the PV modules' connectors to which they are connected:

- Use identical connectors from the same manufacturer and of the same type on both the Power Optimisers and on the modules; or
- Verify that the connectors are compatible in the following way:
- The module connector manufacturer should explicitly verify compatibility with the SolarEdge Power Optimiser connector; and the Inverter DC input connectors.
- A third-party test report by one of the listed external labs (TUV, VDE, Bureau Veritas UL, CSA, InterTek) should be obtained, verifying the compatibility of the connectors.

## Installation Guidelines

- For the minimum and maximum number of Power Optimisers in a PV string (PV string length), see the Power Optimiser datasheets. Refer to the Designer for PV string length verification. The Designer is available on the SolarEdge website at: .
- *Do not* use extension cables between a module and a Power Optimiser, between two modules connected to the same Power Optimiser, or between two Power Optimisers other than in the following cases:

### **Between a Power Optimiser and a module:**

- Extension cables of up to 1.8 m are allowed for all Power Optimisers (0.9 m for DC+, and 0.9 m for DC-).
- P-Series Power Optimisers with the 4-type suffix in their part number (Pxxx-4xxxxxx) and the Mxxx-Series - extension cables of up to 16 m can be installed per Power Optimiser (8 m for DC+, and 8 m for DC-).

### **Between two Power Optimisers or between a Power Optimiser and the inverter:**

- Extension cables can be installed between Power Optimisers only from row to row, around obstacles or pathways within a row and from the end of the PV string to the inverter. The total length of the extension cables may not exceed the following values:

Single Phase Inverters	Three Phase Inverters
All - 300 m	

- Frame-mounted Power Optimisers are mounted directly on the module frame, regardless of racking system (rail-less or with rails). For installation of frame-mounted Power Optimisers, refer to [http://www.solaredge.com/sites/default/files/installing\\_frame\\_mounted\\_power\\_optimizers.pdf](http://www.solaredge.com/sites/default/files/installing_frame_mounted_power_optimizers.pdf).
- The Power Optimiser can be placed in any orientation.
- If connecting more modules than Power Optimiser inputs in parallel, use a branch cable. Some commercial Power Optimiser models have a dual input.
- Position the Power Optimiser close enough to its module so that their cables can be connected.
- Make sure to use Power Optimisers that have the required output and input conductor length.
- Completely shaded modules may cause their Power Optimisers to temporarily shut down. This will not affect the performance of the other Power Optimisers in the PV string, as long as the minimum number of unshaded Power Optimisers connected in a PV string of modules is met. If under typical conditions fewer than the minimum Power Optimisers are connected to unshaded modules, add more Power Optimisers to the PV string. To allow for heat dissipation, maintain clearance shown in
- **All Power Optimisers, except for the P860 and P960 Power Optimisers**

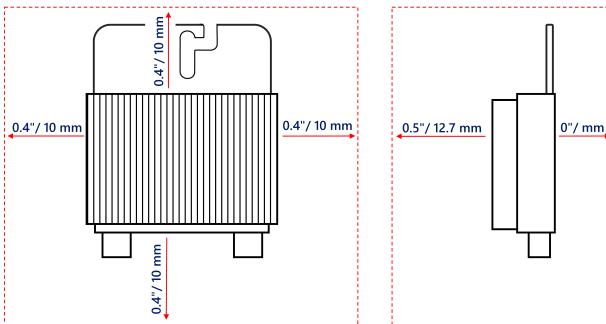

## P860, P960 and M1600 Power Optimisers

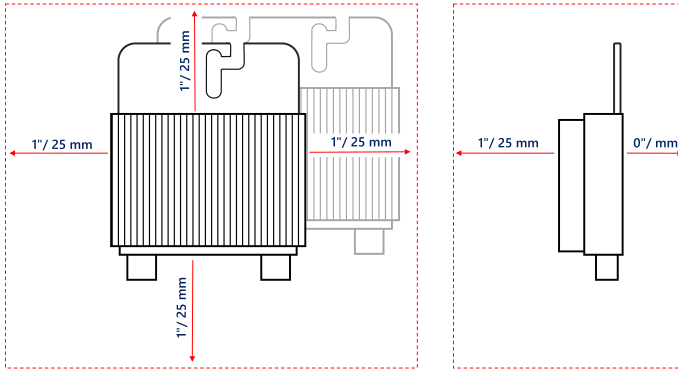

Figure 2: Power Optimisers clearance

- When installing PV modules in a confined space such as Building-integrated photovoltaic (BIPV) modules, ventilation measures may be required to ensure that the Power Optimisers are not exceeding the maximum temperatures stated in their specifications.

## Step 1: Mounting the Power Optimisers

For each of the Power Optimisers<sup>(1)</sup>:

1. Determine the Power Optimiser mounting location and use the Power Optimiser mounting brackets to attach the Power Optimiser to the support structure. It is recommended to mount the Power Optimiser in a location protected from direct sunlight. For frame-mounted Power Optimisers follow the instructions supplied with the optimisers, or refer to [https://www.solaredge.com/sites/default/files/installing\\_frame\\_mounted\\_power\\_optimizers.pdf](https://www.solaredge.com/sites/default/files/installing_frame_mounted_power_optimizers.pdf).
2. If required, mark the mounting hole locations and drill holes.



### CAUTION!



Drilling vibrations may damage the Power Optimiser and will void the warranty. Use a torque wrench or an electric drill with adjustable clutch that meets the mounting torque requirements. *Do not* use impact drivers for mounting the Power Optimiser.

*Do not* drill through the Power Optimiser or through the mounting holes.

3. Attach each Power Optimiser to the rack using M6 or M8 stainless steel bolts, nuts and washers or other mounting hardware. Apply torque of 9-10 N\*m.
4. Verify that each Power Optimiser is securely attached to the module support structure.
5. Record Power Optimiser serial numbers and locations, as described in *Reporting and Monitoring Installation Data* on page 51.

## Step 2: Connecting a PV module to a Power Optimiser

### NOTE



Improper wiring may cause electrical faults in a PV system. To avoid electrical faults, verify proper locking of connectors and avoid cable tension and friction. Proper planning, materials and installation reduce the risk of electric arcs, short-circuits and ground faults in the PV system.

### NOTE



Images are for illustration purposes only. Refer to the label on the product to identify the plus and minus input and output connectors.

For each of the Power Optimisers:

---

<sup>(1)</sup>Not applicable to smart modules.

- Connect the Plus (+) output connector of the module to the Plus (+) input connector of the Power Optimiser.
- Connect the Minus (-) output connector of the module to the Minus (-) input connector of the Power Optimiser.

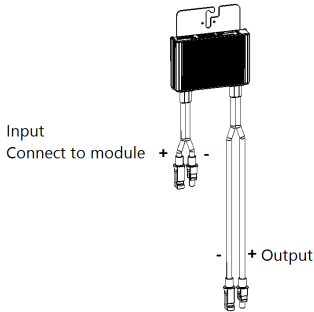

Figure 3: S-Series (left) and P-Series (right) Power Optimiser connectors

## Step 3: Connecting Power Optimisers in PV strings

You can construct parallel PV strings of unequal length, that is, the number of Power Optimisers in each PV string does not have to be the same. The minimum and maximum PV string lengths are specified in the power datasheets. Refer to the SolarEdge Site Designer for PV string length verification.

### NOTE



The DC bus of each unit is separate and not shared for all units. Therefore, in addition to following the inverter design rules, each unit should follow the unit design rules as detailed in the Technical Specifications.

1. Connect the Minus (-) output connector of the PV string's first Power Optimiser to the Plus (+) output connector of the PV string's second Power Optimiser.
2. To minimize electromagnetic interference (EMI), make sure to minimize the distance between the positive and negative DC cables.
3. Connect the rest of the Power Optimisers in the PV string.

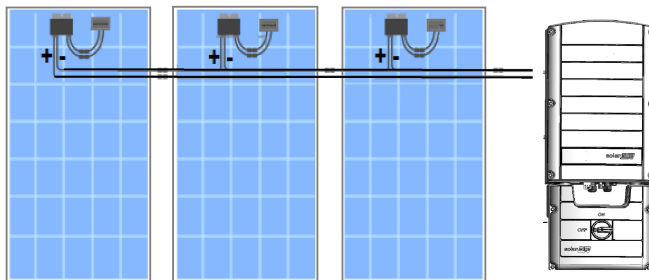

Figure 4: Power Optimisers connected in series

4. If you intend to monitor the installation, using the SolarEdge Monitoring platform, record the physical location of each Power Optimiser, as described in *Creating Logical and Physical Layout using Installation Information* on page 52.

## Step 4: Verifying Proper Power Optimiser Connection

When a module is connected to a Power Optimiser, the Power Optimiser outputs a safe voltage of 1V ( $\pm 0.1V$ ). Therefore, the total PV string voltage should equal 1V times the number of Power Optimisers connected in series in the PV string. For example, if 10 Power Optimisers are connected in a PV string, then 10V should be produced.

Make sure the PV modules are exposed to sunlight during this process. The Power Optimiser will only turn ON if the PV module provides at least 2W.

In SolarEdge systems, due to the introduction of Power Optimisers between the PV modules and the inverter, the short circuit current  $I_{SC}$  and the open circuit voltage  $V_{OC}$  hold different meanings from those in traditional systems.

For more information about the SolarEdge system's PV string Voltage and current, refer to the  *$V_{OC}$  and  $I_{SC}$  in SolarEdge Systems Technical Note*, available on the SolarEdge website at:

[https://www.solaredge.com/sites/default/files/isc\\_and\\_voc\\_in\\_solaredge\\_systems\\_technical\\_note.pdf](https://www.solaredge.com/sites/default/files/isc_and_voc_in_solaredge_systems_technical_note.pdf)



→ To verify proper Power Optimiser connection:

- Measure the voltage of each PV string individually before connecting it to the other PV strings or to the inverter. Verify correct polarity by measuring the PV string polarity with a voltmeter. Use a voltmeter with at least 0.1V measurement accuracy.

NOTE



Since the inverter is not yet operating, you may measure the PV string Voltage and verify correct polarity on the DC wires inside the Connection UnitDC Safety Unit.

For troubleshooting Power Optimiser operation problems, refer to *Power Optimiser Troubleshooting* on page 57.

Proper Power Optimiser connection can also be verified in the Designer application.

For more information, refer to

<https://www.solaredge.com/products/installer-tools/designer#/>.



## Step 5: Connecting the Strings to a Combiner Box

For connecting the strings to the DC Safety Unit with glands using a single input connection use a combiner box. The combiner box should reside between the modules and the inverter.

# Chapter 3: Installing the Inverter

## Package Contents

- Mounting bracket kit
- Quick installation guide
- Warranty card
- Safety instructions page
- Technical Specifications page

## Identifying the Inverter

Refer to the sticker on the inverter that specifies its **Serial Number** and its **Electrical Ratings**. Provide the serial number when contacting SolarEdge support. The serial number is also required when opening a new site in the monitoring platform.

## Inverter Interfaces

Figure 5 shows an inverter with a DC Safety Unit, located at the bottom of the inverter.

**NOTE**  
The DC Safety Unit is applicable based on the inverter model and country of installation.

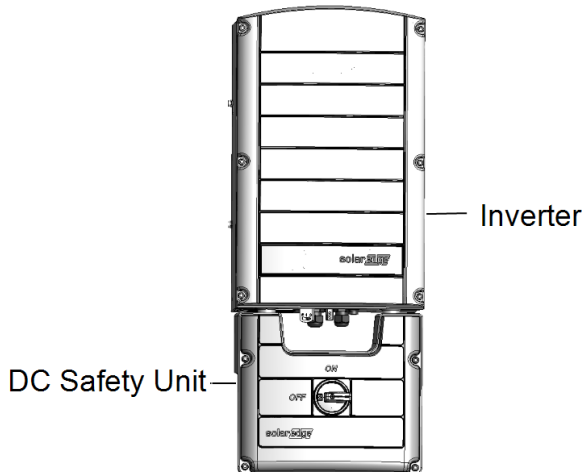

Figure 5: Inverter front view

Figure 6 shows the inverter connectors and components, located at the bottom of the inverter.

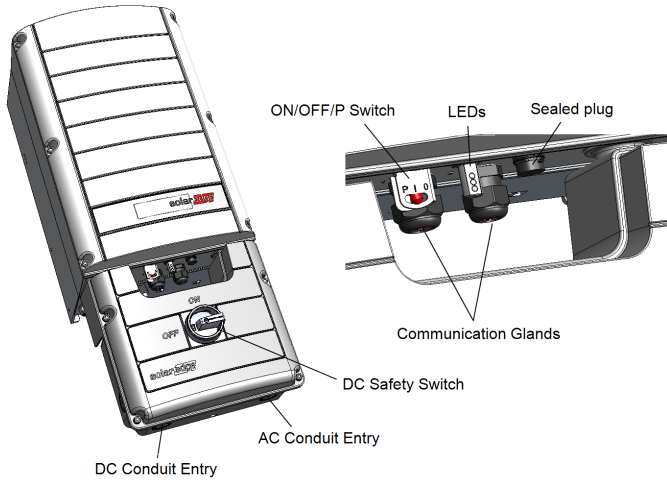

Figure 6: Inverter interfaces

- **AC and DC conduit entries:** Connection entry points of the DC Safety Unit.
- **Two communication glands:** for connection of inverter communication options. Each gland has three openings. Refer to *Setting Up Communication with the Monitoring Platform* on page 37 for more information.
- **P/ON/OFF switch:**

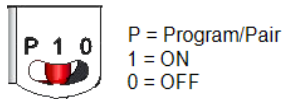

Figure 7: ON/OFF/P switch

- **ON (1)** - Turning this switch ON (after Power Optimiser pairing) starts the operation of the Power Optimisers, enables power production and allows the inverter to begin exporting power to the utility grid.
- **OFF (0)** - Turning this switch OFF reduces the Power Optimiser Voltage to a low safety Voltage and inhibits exportation of power. When this switch is OFF, the control circuitry remains powered up.

- P - Moving and releasing the switch allows viewing system information via the LEDs, and performing the following functions:

P Position Duration	Function	Comments
Switch moved to P for <b>2 seconds</b> , then released.	<ul style="list-style-type: none"> <li>• Displays (via LEDs) production information for 5 seconds, or error type indications (if exist) for 5 seconds.</li> <li>• Activates the Wi-Fi access point for connecting to the SetApp</li> </ul>	<p>While the switch is in P, all LEDs are ON.</p> <p>When the switch is released all LEDs turn OFF for 0.5 sec and then display the production or error indication.</p>
Switch moved to P for <b>more than 5 seconds</b> , then released.	Starts pairing	Pairing is indicated by all 3 LEDs blinking simultaneously.

**LEDs:** three LEDs indicate, by color and state (on/ off/ blinking<sup>(1)</sup>/ flickering<sup>(2)</sup>/alternating<sup>(3)</sup>), different system information, such as errors or performance indications. For more information, refer to <https://www.solaredge.com/leds>.



The main LED indications are:

- Blue ON - the inverter is communicating with the monitoring platform
- Green ON - the system is producing
- Green blinking - AC is connected but the system is not producing
- Red ON - system error

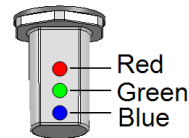

Figure 8: LED indicators

(1)Blinking = Turns ON and OFF for the same duration

(2)Flickering = Turns ON for 100 ms and turns OFF for 5 seconds

(3)Alternating = Alternate LED flashes

The following table describes system performance information by LED color and ON/OFF/P switch position.

Indication	ON/ OFF/ P Switch Position	LED Color			Comment
		Red	Green	Blue	
Power Optimisers not paired	ON (1)	OFF	Blinking	<ul style="list-style-type: none"> <li>• S_OK: ON</li> <li>• No S_OK: OFF</li> </ul>	S_OK: ON communication with the monitoring platform is established.
Pairing		Blinking	Blinking	Blinking	
Wake-up/ Grid Monitoring		OFF	Blinking	Blinking	
System Producing		OFF	ON	<ul style="list-style-type: none"> <li>• S_OK: ON</li> <li>• No S_OK: OFF</li> </ul>	For detailed percentage of production, refer to the following table.
Night mode (no production)		OFF	Flickering	<ul style="list-style-type: none"> <li>• S_OK: ON</li> <li>• No S_OK: OFF</li> </ul>	
Inverter is OFF (Safe DC)	OFF (0)	OFF	Blinking	<ul style="list-style-type: none"> <li>• S_OK: ON</li> <li>• No S_OK: OFF</li> </ul>	
Inverter is OFF (DC not safe)		Blinking	Blinking	<ul style="list-style-type: none"> <li>• S_OK: ON</li> <li>• No S_OK: OFF</li> </ul>	
Inverter configuration or reboot	ON / P	ON	ON	ON	
Inverter firmware upgrade	ON / P	Alternating	Alternating	Alternating	The upgrade process can take up to 5 minutes
Error	Any	ON	ON/ OFF/ Blinking/ Flickering	ON/ OFF / Blinking	Refer to <i>Errors and Troubleshooting</i> on page 55

The following table describes production percentage of AC information by LED color and ON/OFF/P switch position.

Indication	ON/ OFF/ P Switch Position	LED Color			Comment
		Red	Green	Blue	
Percentage of AC Production: 0 %	ON (1)	OFF	OFF	OFF	This indicates power production as percentage of rated peak AC output power
Percentage of AC Production: 0 - 33 %		OFF	ON	OFF	
Percentage of AC Production: 33 - 66 %		OFF	OFF	ON	
Percentage of AC Production: 66 - 100 %		OFF	ON	ON	

## DC Safety Unit Interfaces

- The DC Safety Unit, includes:
  - **ON/OFF switch:** For connection/disconnection of the DC power from the PV strings
  - **AC conduit entries** for connection of AC cable to the grid
  - **DC conduit entries** for connection of the DC wires from the PV strings

**NOTE**



Open the required AC and DC conduit drill guides according to the conduits used in the installation. Taking care not to interfere with any of the internal components. It is recommended to use a Unibit drill. Use 19.1 mm or 25.4 mm Unibit drill to create holes for AC and DC conduits.

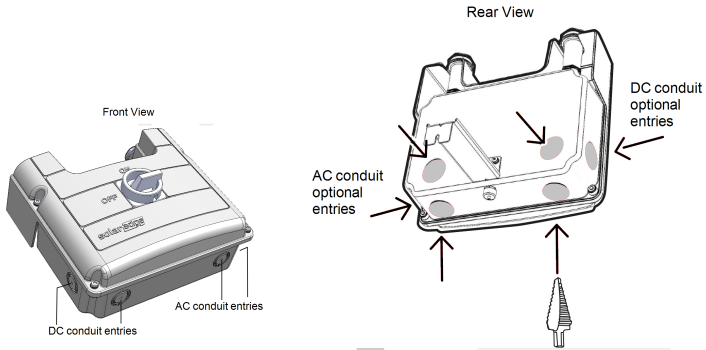

Figure 9: DC Safety Unit conduit entries

**NOTE**

When the safety switch of the DC Safety Unit is OFF (for example during maintenance) it may be locked to prevent a safety hazard. To lock the switch:



1. Move the switch to the lock position.
2. Insert the lock through the knob opening and lock.



Lock here

## Mounting the Inverter

The inverter is supplied with a mounting bracket kit:

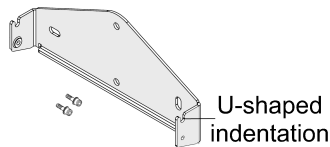

Figure 10: Mounting bracket kit

**NOTE**

Make sure the mounting surface or structure can support the weight of the inverter.

**CAUTION!**

SolarEdge inverters and Power Optimisers can be installed at a minimum distance of 50 m from the shoreline of an ocean or other saline environment, as long as there are no direct salt water splashes on the inverter or Power Optimiser.

For SolarEdge inverters installed at a distance of 200 m or closer to the shoreline, special brackets purchased separately from SolarEdge and SS304 stainless screws are required.

1. Determine the inverter mounting location, on a wall, rails, stud framing or pole. It is recommended to mount the inverter in a location protected from direct sunlight.

**NOTE**

To avoid wobbly installation of the inverter on rails or stud framing, use a supporting rail on the back of the DC Safety Unit (see *Figure 11*).

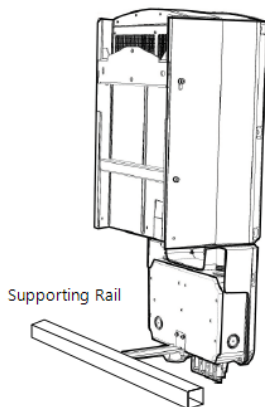

Figure 11: Supporting rail on the back of the DC Safety Unit

2. To allow proper heat dissipation, maintain the following minimum clearance areas between the inverter and other objects as described at: <https://www.solaredge.com/sites/default/files/se-clearance-guidelines-for-multiple-inverter-mounting.pdf>

Verify that the fan, located at the bottom of the inverter, is not blocked and that air can flow freely.



Figure 12: Inverter fan - airflow

**CAUTION!**

Do not block the airflow from the inverter.

→ **To mount the inverter:**

1. Position the mounting bracket against the wall/pole and mark the drilling hole locations (refer to *Mechanical Specifications* on page 1 for inverter and mounting bracket dimensions).
2. Drill at least two holes and mount the bracket to the mounting surface. Verify that the bracket is firmly attached to the mounting surface.
3. Hang the inverter on the bracket (See *Figure 13*):
  - a. Lift the inverter from the sides, or hold it at the top and bottom. Do not lift holding the DC Safety Unit as it may be damaged.
  - b. Lower the inverter onto the U-shaped indentations of the mounting bracket. Let the inverter lay flat against the wall or pole

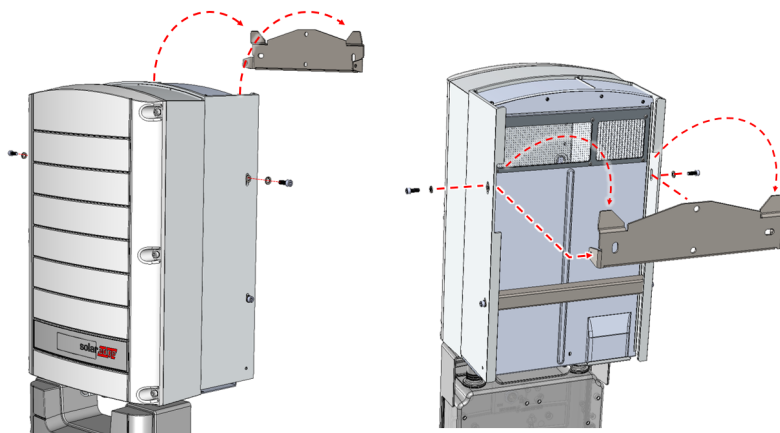

Figure 13: Hanging the inverter on the brackets

4. Mark the location of the drilling hole required for the screw that secures the bracket of the DC Safety Unit to the wall (See *Figure 14*) and remove the inverter from the wall.

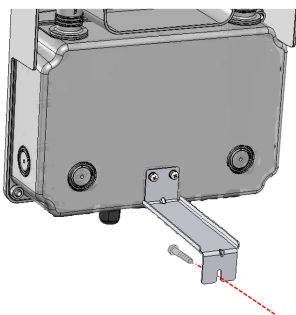

Figure 14: Securing the DC Safety Unit to the wall

5. Drill a hole for the screw anchor securing DC Safety Unit to the wall.
6. Hang the inverter on the bracket (See *Figure 13*):
  - a. Lift the inverter from the sides, or hold it at the top and bottom. Do not lift holding the DC Safety Unit as it may be damaged.
  - b. Lower the inverter onto the U-shaped indentations of the mounting bracket. Let the inverter lay flat against the wall or pole.
  - c. Insert the two supplied screws through the outer heat sink fin on both sides of the inverter and into the bracket. Tighten the screws with a torque of 4.0 N\*m

7. Use a screw to secure the bracket that secures DC Safety Unit to the wall.
8. Verify that the inverter is firmly attached to the mounting surface.

## Grounding the Inverter

In some locations, local regulations requires grounding the chassis of the inverter. If the inverter is installed indoors, a ground wire should be connected to a building electrical ground point. If the Inverter is installed outdoors, connect the inverter chassis with a ground wire to a properly grounded point.

→ To connect the inverter to a Ground point:

1. Connect the lug of a Ground Wire to the Ground Point on either the right or left hand side of the inverter chassis.

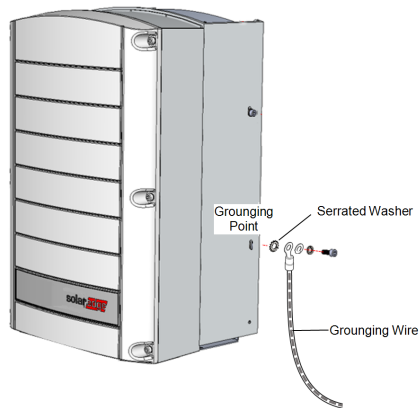

Figure 15: Grounding the inverter

2. Connect the lug on the other side of the Ground Wire to the building electrical Ground point or properly grounded point.

## Chapter 4: Connecting Grid and PV Strings to the Inverter

This chapter describes how to connect the inverter to the AC grid and to the Power Optimiser of the PV modules on the strings.

Operational settings including grid protection settings may be reviewed periodically as part of a routine maintenance procedure.

### Grid Connection Guidelines

Prior to system installation, refer to the following documentation:

- Three Phase Inverters for 3-Wire Grids application note at: [https://www.solaredge.com/sites/default/files/se\\_three\\_phase\\_inverters\\_for\\_delta\\_grids.pdf](https://www.solaredge.com/sites/default/files/se_three_phase_inverters_for_delta_grids.pdf)
- Grids Supported by SolarEdge Inverters application note at: [https://www.solaredge.com/sites/default/files/grids\\_supported\\_by\\_se\\_inverters\\_europe\\_and\\_apac.pdf](https://www.solaredge.com/sites/default/files/grids_supported_by_se_inverters_europe_and_apac.pdf)
- Countries Supported by the SolarEdge Inverters application note (to confirm compatibility) at: [https://www.solaredge.com/sites/default/files/se\\_inverters\\_supported\\_countries.pdf](https://www.solaredge.com/sites/default/files/se_inverters_supported_countries.pdf). Installing without confirmation may void the inverter warranty.
- For recommended circuit breaker size per model refer to Determining the Circuit Breaker Size application note at <https://www.solaredge.com/sites/default/files/determining-the-circuit-breaker-size-for-three-phase-inverters.pdf>
- For short-circuit currents in SolarEdge Three Phase Inverters refer to Short-Circuit Currents in SolarEdge Three Phase Inverters application note at <https://www.solaredge.com/sites/default/files/se-short-circuit-currents-three-phase-inverters-tech-note.pdf>

#### NOTE



For more wiring information refer to the *SolarEdge Recommended AC Wiring Application Note*, available on the SolarEdge website at <https://www.solaredge.com/sites/default/files/application-note-recommended-wiring.pdf>



## Connecting to the AC Grid

Use a standard AC cable with five wires (L1, L2, L3 + N + PE) or four wire (L1, L2, L3 + PE). The cross section of the conductor of each wire must be 4 mm<sup>2</sup> to 16 mm<sup>2</sup>.

For more wiring information, refer to the *SolarEdge Recommended AC Wiring Application Note*, available on the SolarEdge website at <http://www.solaredge.com/files/pdfs/application-note-recommended-wiring.pdf>.



## Connecting the AC Grid to the Inverter

→ To connect the AC grid to the inverter:

1. Turn-off the AC circuit breaker of the inverter on the distribution panel.
2. Turn-off the ON/OFF/P switch of the inverter.
3. Turn-off the DC switch of the DC Safety Unit.
4. Release the six Allen screws and carefully remove the cover of the inverter by pulling out and lowering it down.
5. Release the four Allen screws and remove the cover of the DC Safety Unit.

### CAUTION!



When removing covers, make sure not to damage internal components. SolarEdge will not be held responsible for any components damaged as a result of incautious cover removal.

6. Route the AC wires through the conduit into the DC Safety Unit and towards the AC Terminal Block inside the inverter (see *Figure 16*).

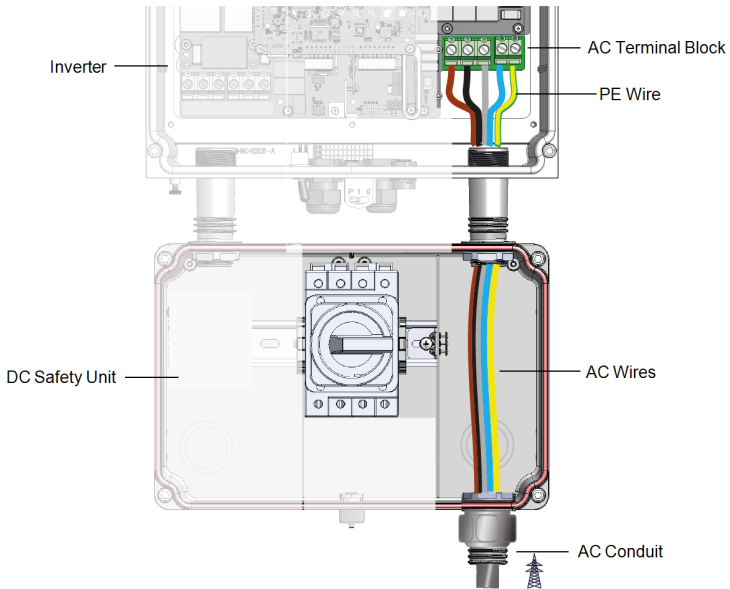

Figure 16: AC cable route inside the DC Safety Unit and inverter

7. Strip 10 mm to 11 mm of the AC wires insulation.

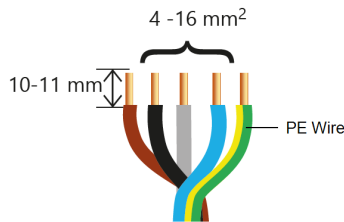

Figure 17: Stripping insulation from the AC wires

8. Connect the wires of the AC cable according to the labels on the AC terminal block of the inverter (see *Figure 18*). Tighten the screws of the Terminal Blocks with a torque of 1.2-1.5 N\*m.

**WARNING!**



Always connect the Protective Earth (PE) wire first. The Ground point of the inverter and the PE terminal of the DC Safety Unit are linked by a grounding wire. Do not disconnect the wire on either side!



**NOTE**

When using a stranded wire, the use of ferrule is at the installer discretion.

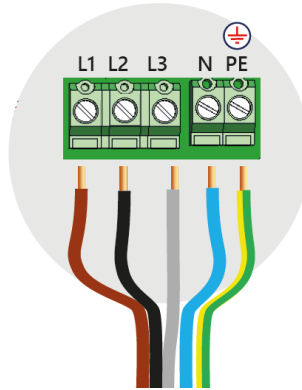

Figure 18: Connecting wires to the terminal block

9. Verify that all wires inside the Inverter are firmly tightened to the AC terminal block. Check that the wires are fully inserted and cannot be pulled out easily.
10. Close the inverter cover and tighten the screws with a torque of  $9 \text{ N}^*\text{m}$  /  $10.3 \text{ N}^*\text{m}$  (for plastic screws).
11. Close the cover of the DC Safety Unit and tighten the screws with a torque of  $9 \text{ N}^*\text{m}$  /  $10.3 \text{ N}^*\text{m}$  (for plastic screws).

## Connecting the PV Array to the Inverter

Connect the PV arraystring to the DC input pairs. Inverters with the DC Safety Unit, may have MC4 connectors or glands for PV string connection. Additional PV arrays can be added to the system by parallel connection using an external combiner box or branch cables. Installation and connection of the combiner box must be done before connecting to the inverter or DC Safety Unit.

### NOTE

- Functional electrical earthing of DC-side negative or positive poles is prohibited because the inverter has no transformer. Grounding (earth ground) of module frames and mounting equipment of the PV array modules is acceptable.

### NOTE

- SolarEdge fixed input voltage architecture enables the parallel arrays to be of different lengths. Therefore, they do not need to have the same number of power optimizers, as long as the length of each string is within the permitted range.

## NOTE



It is important that when installing a system with more than 3 strings per a single Synergy Unit (whether connected directly or via a combiner box), fuses are required. In SolarEdge system, 25A fuses shall be used.

## Connecting PV Array to the DC Safety Unit

When wiring the inverter, the cross section of the conductor of the DC wires must be 6 mm<sup>2</sup> to 35 mm<sup>2</sup>. When using a stranded wire, the use of ferrule is at installer discretion. Bi-metal ferrule must be used for aluminum conductor.

→ To connect a single input to the DC safety switch:

1. Connect the strings to the combiner box, if you have not already connected it.
2. Turn OFF the following:
  - The ON/OFF/P Switch of the inverter
  - The DC Safety Switch on the DC Safety Unit
  - The AC circuit breaker on AC distribution panel
3. Loosen and remove the six Allen screws on the front cover of the inverter and carefully remove the cover.

## CAUTION!



When removing the cover, make sure not to damage internal components. SolarEdge will not be held responsible for any components damaged as a result of incautious cover removal.

4. Loosen and remove the four screws on the front cover of the DC Safety Unit and carefully remove the cover.

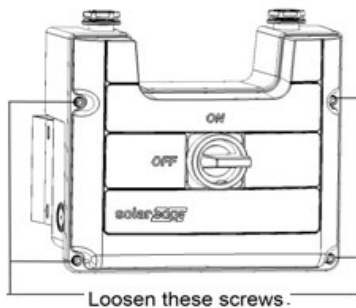

Figure 19: Removal of DC Safety Unit cover

5. Route the DC wires through the conduit and into the DC Safety Unit.

- Strip 25 mm of the DC wires insulation.

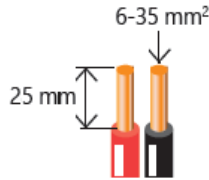

Figure 20: Stripping insulation from the DC wires

- Connect the DC wires according to the DC+ and DC- labels:

Use a standard flat-blade screwdriver to connect the wires to the spring-clamp terminals.

- The screwdriver blade should fit freely in the terminal opening. Too large a blade can crack the plastic housing.
- Insert the screwdriver and press the release mechanism and open the clamp.
- Insert the conductor into the opening and remove the screwdriver – the wire is automatically clamped.

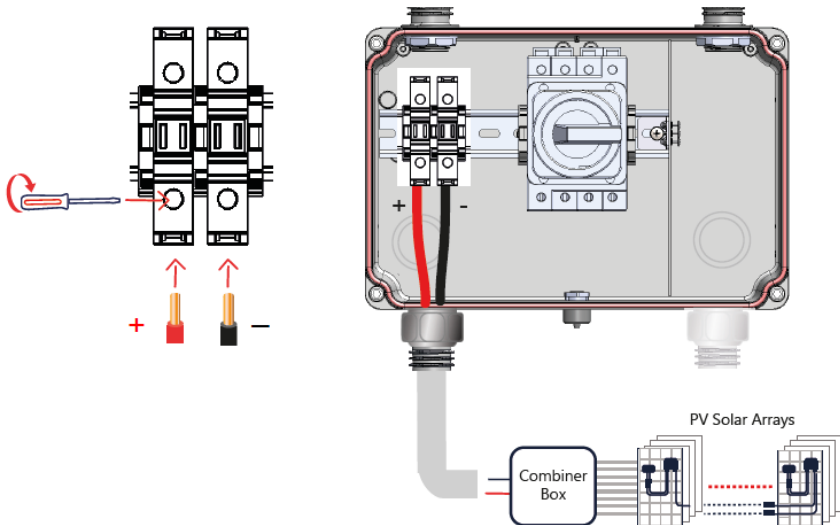

Figure 21: Connecting the DC wires inside the DC Safety Unit

- Verify that the wires are firmly connected.
- Close the DC Safety Unit cover: attach the cover and secure it by tightening the four

screws to a torque of 9 N\*m / 10.3 N\*m (for plastic screws)

10. Close the inverter cover: Attach the cover and secure it by tightening the six screws with a torque of 9.0 N\*m / 10.3 N\*m (for plastic screws).
11. Ensure proper cable entry sealing: inspect the entire cable run and use standard sealants to avoid water penetration.

# Chapter 5: Setting Up Communication with the Monitoring Platform

The inverter sends the following information to the monitoring platform:

- Power Optimiser information received via the DC power lines (the PV output circuit)
- Inverter information
- Information of any other connected devices

This chapter describes how to set up communication between:

- The inverter and the monitoring platform through the Internet (wired/ wireless)
- Multiple inverters for a leader-follower configuration

Communication setup is not required for power harvesting, however it is needed for using the monitoring platform.

## CAUTION!



When connecting the communication cables, make sure that the ON/OFF/P switch on the inverter is turned OFF, the DC Disconnect Switch on the Connection Unit is turned OFF and the AC is turned OFF.

When configuring the communication parameters, make sure that the ON/OFF/P switch on the inverter is OFF, and the AC is turned ON.

## Communication Options

The following types of communication can be used to transfer the monitored information from the inverter to the monitoring platform.

## NOTE



This guide refers to 3rd party communication products, such as internet switches and routers that are not supported by SolarEdge. For detailed information on how to install and use the products, refer to the respective publication provided with each product.

## Ethernet

Ethernet is used for a LAN connection. For connection instructions refer to "Creating an Local Area Network (LAN) Connection" on page 1 *Creating an Ethernet (LAN) Connection* on page 40 *Creating an Ethernet (LAN) Connection* on page 40

## RS485

RS485 is used for the connection of multiple SolarEdge devices on the same bus in a leader-follower configuration. RS485 can also be used as an interface to external devices, such as meters and third party data loggers.

- RS485-1: Enables the connection of multiple devices (inverters/Commercial Gateway) over the same bus, such that connecting only one device to the internet is sufficient to provide communication services for all the devices on the bus.
- RS485-2: Enables connection of multiple SolarEdge devices and of non-SolarEdge devices over the same bus.

For connection instructions refer to *Creating an RS485 Bus Connection* on page 44.

## Cellular

Cellular Plug-in (purchased separately) provides cellular communication to connect one or several inverters to the Monitoring platform. Cellular communication depends on the purchased data plan.

## Communication Connectors

Two communication glands are used for connection of the various communication options. Each gland has three openings. The table below describes the functionality of each opening. Unused openings should remain sealed.

Gland#	Opening	Functionality	Cable size (diameter)
<b>Com 1</b> (PG16)	One small	External antenna cable	2-4 mm
<b>Com 2</b> (PG13.5)	All three	RS485	2.5-5 mm

Figure 22: Communication Glands

The communication board has a standard RJ45 terminal block for Ethernet connection, and a 6-pin terminal block for RS485 connection, as shown below:

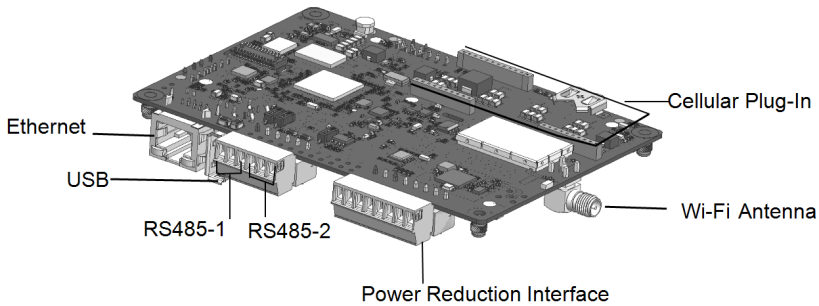

Figure 23: Internal communication connectors

## Removing the Inverter Cover

→ To remove the inverter cover

1. Switch off the AC circuit breaker on the main distribution panel.
2. Switch off the inverter ON/OFF/P switch and wait 5 minutes for the internal capacitors to discharge.
3. Turn the DC Disconnect Switch to OFF.
4. Open the Allen screws of the inverter cover and carefully pull the cover horizontally before lowering it.
5. Open the inverter cover.

### CAUTION!



When removing the inverter cover, make sure not to damage the internal components. SolarEdge will not be held responsible for any components damaged as a result of incautious cover removal.

## Removing the DC Safety Unit Cover

1. Switch off the AC circuit breaker on the main distribution panel and the safety switch (if applicable).
2. Open the DC Safety Unit cover: Release the four Allen screws and remove the cover.

### CAUTION!



When removing the DC Safety Unit cover, make sure not to damage the internal components. SolarEdge will not be held responsible for any components damaged as a result of incautious cover removal.

## Creating an Ethernet (LAN) Connection

This communication option enables using an Ethernet connection to connect the inverter to the monitoring platform via LAN.

Ethernet cable specifications:

- Cable type – a shielded Ethernet cable (CAT6 may be used).
- Maximum distance between the inverter and the router – 100 m/ 330 ft.

**NOTE**



If using a cable longer than 10 m / 33 ft in areas where there is a risk of induced voltage surges by lightning, it is recommended to use external surge protection devices.

For details refer to: .

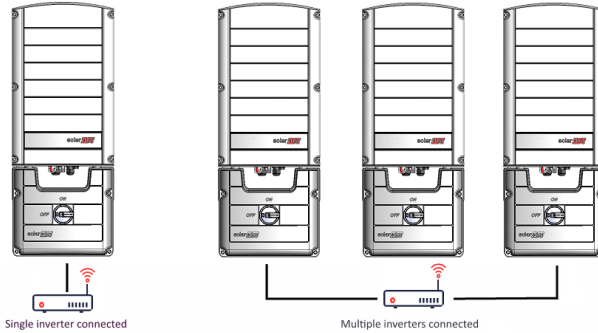

Example of Ethernet connection

→ To connect the Ethernet cable:

1. Remove the inverter cover as described *Removing the Inverter Cover* on page 40
2. Open the communication gland #1.

**CAUTION!**



The gland includes a rubber waterproof fitting, which should be used to ensure proper sealing.

3. Remove the plastic seal from one of the large opening.
4. Remove the rubber fitting from the gland and insert the CAT6 cable through the gland and through the gland opening in the inverter.
5. Push the cable into the cut opening of the rubber fitting.

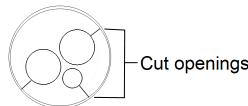

Figure 24: Rubber fitting

CAT6 standard cables have eight wires (four twisted pairs), as shown in the diagram below. Wire colors may differ from one cable to another. You can use either wiring standard, as long as both sides of the cable have the same pin-out and color-coding.

RJ45 Pin #	Wire Color <sup>(1)</sup>		10Base-T Signal 100Base-TX Signal
	T568B	T568A	
1	White/Orange	White/Green	Transmit+
2	Orange	Green	Transmit-
3	White/Green	White/Orange	Receive+
4	Blue	Blue	Reserved
5	White/Blue	White/Blue	Reserved
6	Green	Orange	Received-
7	White/Brown	White/Brown	Reserved
8	Brown	Brown	Reserved

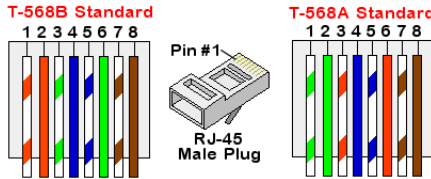

Figure 25: Standard cable wiring

6. Use a pre-crimped cable to connect via gland #1 to the RJ45 plug on the inverter's communication board or, if using a spool of cable, connect as follows:
  - a. Insert the cable through gland #1.
  - b. Remove the cable's external insulation using a crimping tool or cable cutter and expose eight wires.
  - c. Insert the eight wires into an RJ45 connector, as described in *Figure 25*.
  - d. Use a crimping tool to crimp the connector.
  - e. Connect the Ethernet connector to the RJ45 port on the communication board.

---

<sup>(1)</sup>The connection does not support RX/TX polarity change. Supporting crossover Ethernet cables depends on the switch capabilities.

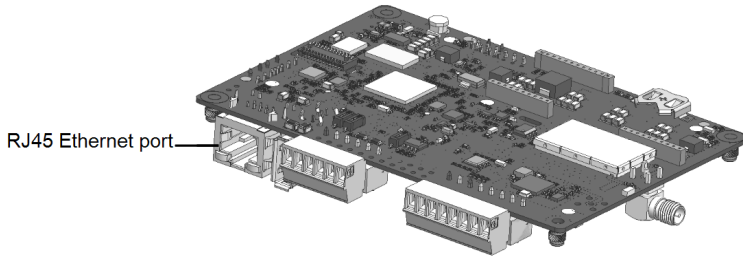

Figure 26: The RJ45 Ethernet connection

7. For the switch/router side, use a pre-terminated cable or use a crimper to prepare an RJ45 communication connector: Insert the eight wires into the RJ45 connector in the same order as above (*Figure 25*).
8. Connect the cable RJ45 connector to the RJ45 port of the Ethernet switch or router. You can connect more than one inverter to the same switch/router or to different switches/routers, as needed. Each inverter sends its monitored data independently to the monitoring platform.
9. The inverter is configured by default to LAN. If reconfiguration is required:
  - a. Make sure the ON/OFF/P switch is OFF.
  - b. Turn ON the DC Safety Unit
  - c. Turn ON the AC to the inverter by turning ON the circuit breaker on the main distribution panel.
  - d. Configure the connection as described in *Communication* on page 50.

#### NOTE



If your network has a firewall, you may need to configure it to enable the connection to the following address:

- Destination Address: prod2.solaredge.com
- TCP Port: 22222, 22221, or 80 (for incoming and outgoing data)

10. Verify the connection, as described in *Verifying the Connection* on page 47.

## Creating an RS485 Bus Connection

The RS485 option enables creating a bus of connected inverters, consisting of up to 31 follower inverters and 1 leader inverter. Using this option, inverters are connected to each other in a bus (chain), via their RS485 connectors. The first and last inverters in the chain must be terminated as described on page 45.

RS485 wiring specifications:

- Cable type: CAT6
- Maximum nodes: 32
- Maximum distance between first and last devices: 1 km /3300 ft

### NOTE



If grounded metal conduits are used for routing the communication wires, a lightning protection device is not required.

The following sections describe how to physically connect the RS485 bus and how to configure the bus.

→ To connect the RS485 communication bus:

1. Release the six Allen screws and carefully remove the DC Safety Unit cover
2. Remove the seal from one of the openings in communication gland #2 and insert the wire through the opening.
3. Pull out the 6-pin RS485 terminal block connector, as shown in *Figure 27*.

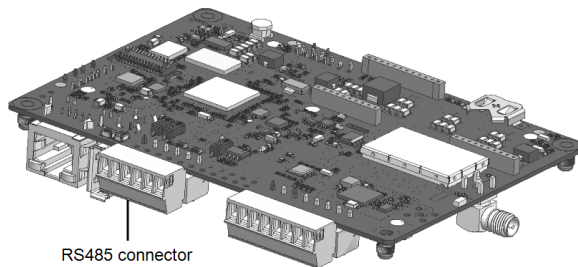

Figure 27: RS485 terminal block on the communication board

4. Loosen the screws of pins A(+), B(-), and G on the left of the RS485 terminal block (RS485-1 or RS485-2).

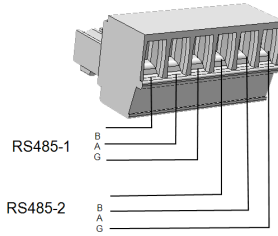

Figure 28: RS485 terminal block

5. Insert the wire ends into the **G**, **A** and **B** pins shown above. Use Four- or six-wire twisted pair cable for this connection.

You can use any color wire for each of the **A**, **B** and **G** connections, as long as:

- The same color wire is used for all A pins the same color for all B pins and the same color for all G pins
- The wire for G is not from the same twisted pair as A or B.

6. For creating an RS485 bus - connect all B, A and G pins in all inverters. The following figure shows this connection schema:

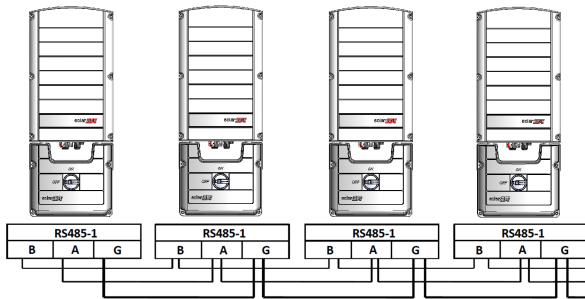

Figure 29: Connecting the inverters in chain



**NOTE**

Do not cross-connect B, A and G wires.

7. Tighten the terminal block screws.
8. Check that the wires are fully inserted and cannot be pulled out easily.
9. Push the RS485 terminal block firmly all the way into the connector on the right side of the communication board.
10. Terminate the first and last SolarEdge device in the chain by switching a termination

DIP-switch inside the inverter to ON (move the left switch up). The DIP-switch is located on the communication board and is marked SW1.

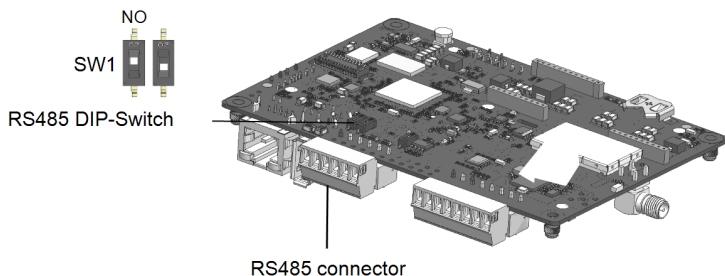

Figure 30: RS485 termination DIP-switch (SW1)

#### NOTE



Only the first and last SolarEdge devices in the chain should be terminated. The other inverters in the chain should have the termination switch OFF (down position).

11. Tighten the nut of the COMM2 gland in a torque of 4 N\*m.

## RS485 Bus Configuration

→ To connect to the monitoring platform:

1. Designate a single inverter as the connection point between the RS485 bus and the monitoring platform. This inverter will serve as the leader inverter.
2. Connect the leader to the monitoring platform using Ethernet (refer to *Creating an Ethernet (LAN) Connection* above).

→ To configure the RS485 bus:

All inverters are configured by default as followers. To configure the leader:

1. Make sure the inverter's ON/OFF/P switch is off.
2. Make sure that the AC circuit breaker on the main distribution panel is on.
3. Turn-on the on the DC Safety Unit .
4. Access SetApp, as described in *Communication* on page 50.
5. From the **Commissioning** screen, select **Site Communication** > **RS485-1** > **Protocol** > **SolarEdge** > **SolarEdge Leader**.
6. Return to the **RS485-1** screen and select **Follower Detect**.

The system starts automatic detection of the follower inverters connected to the leader inverter. The inverter should report the correct number of followers. If it does not, verify the connections and terminations in all inverters in the chain.

7. To check the follower IDs and last communication time, select **RS485-1 > Follower List**.
8. Verify the connection of the leader to the monitoring platform, as described below.

## Verifying the Connection

After connecting and configuring a communication option, perform the following steps to check that the connection to the Monitoring platform has been successfully established.

1. If the DC Safety Unit cover is not closed, close it: Attach the DC Safety Unit cover and secure it by tightening the screws with a torque of 3.5 N\*m. For proper sealing, first tighten the corner screws and then the two central screws.
2. Commission the inverter as describe in "**Activating, Commissioning and Configuring the System**" on page 48.
3. Access SetApp and select **Status** from the **Configuring** screen.
4. In the **Summary** section, under **Server Comm.**, make sure **S\_OK** is displayed together with the selected communication option.
5. Scroll down to the **Communication** section and check that the communication options are as required.

# Chapter 6: Activating, Commissioning and Configuring the System

After the solar system is installed, it is important to activate and commission the solar system. Activation and commission of the system is performed using the inverter SetApp mobile application.

During the activation and commissioning, the inverter discovers and communicates with all connected components in the solar system, such as: optimizers, peripheral communication devices and other linked inverters. When commissioning is performed, the user is required to set the grid parameters and backup Voltage information (if used). Before starting the activation and commissioning, verify the all the communication hardware is properly connect. For communication options, refer to: *Setting Up Communication with the Monitoring Platform* on page 37.

Before arriving at the site, download SolarEdge SetApp application to your mobile device from Apple App Store or Google Play .

Before activation and commissioning, download the SetApp application from:



For downloading SetApp, Internet connection, one-time registration and logging are required. No registration is required for using the SetApp.

## Step 1: Activating the Installation

During system activation, a Wi-Fi connection is created between the mobile device and the inverter and the system firmware is upgraded.

### Before activation

- Download, register (first time only) and login to SetApp on your mobile device. Verify that the application is updated with the latest version.

- If applicable, turn on all devices (battery, Energy Meter) connected to the inverter, so that the devices may be auto-detected.
- To activate the inverter:
  1. Turn-on the AC circuit breaker on the main distribution panel.
  2. Turn-on the DC Disconnect Switch (if applicable).
  3. Open SetApp and follow the on-screen instructions (scan the inverter barcode; move the ON/OFF/P switch to P position for 2 seconds and release).  
SetApp creates a Wi-Fi connection, upgrades the inverter firmware and activates the inverter.
  4. When the activation is complete, do one of the following:
    - Select **Connect to Another Device** to continue activating additional inverters.
    - Select **Start Commissioning** for pairing and other system configuration.

## Step 2: Commissioning and Configuring the Installation

This section describes how to use the SetApp menus for commissioning and configuring the inverter settings.

Menus may vary in your application depending on your system type.

→ To access the Commissioning screen:

Do one of the following:

- During first time installation: Upon activation completion, in the SetApp, tap **Start Commissioning**.
- If the inverter has already been activated and commissioned:
  - If not already ON - turn ON AC to the inverter by turning ON the circuit breaker on the main distribution panel.
  - Open SetApp and follow the on-screen instructions (scan the inverter QR code, move the ON/OFF/P switch to P position for 2 seconds and release).  
The mobile device creates a Wi-Fi connection with the inverter and displays the main Commissioning screen.

## Setting Country, Grid and Language

The inverter must be configured to the proper settings in order to ensure that it complies with the country grid code and functions. Unless these settings are selected, the inverter will not start production.

1. From the **Commissioning** screen, select **Country & Grid**.
2. From the **Country & Grid** drop-down list, select the required option and tap **Set Country & Grid**. If unsure, which regional grid code (Australia A, B, or C) to select, contact your local grid operator to confirm the settings.
3. If relevant, from the **Language** drop-down list, select your language and tap **Set Language**.
4. From the **Commissioning** screen, select **Power Control** and make sure all settings are correct.
5. From the **Commissioning** screen, select **Grid Protection** and make sure all settings are correct.
6. To save the information to a read-only file, tap the **PDF** icon (iOS) or the **JPEG** icon (Android) at the bottom of the screen.

## Pairing

1. From the **Commissioning** menu, select **Pairing**.
2. Tap **Start Pairing**.
3. When **Pairing Complete** is displayed, the system startup process begins:  
Since the inverter is ON, the Power Optimisers start producing power and the inverter starts converting AC.

### WARNING!



When you turn ON the ON/OFF/P switch, the DC cables carry a high Voltage and the Power Optimisers no longer output a safe output.

When the inverter starts converting power after the initial connection to the AC, the inverter enters Wake up mode until its working voltage is reached. This mode is indicated by the flickering green inverter LED.

When working voltage is reached, the inverter enters Production mode and produces power. The steadily lit green inverter LED indicates this mode.

4. Tap **OK** to return to the **Commissioning** menu.

## Communication

Communication settings can be configured only after communication connections are complete. Refer to *Setting Up Communication with the Monitoring Platform* on page 37.

- Select **Monitoring Communication** to configure communication with the monitoring platform.

- Select **Site Communication** to configure communication between multiple SolarEdge devices or external non-SolarEdge devices, such as batteries or loggers.

## Power Control

### Step 3: Verifying Proper Activation and Commissioning

1. Select **Information** and verify that the correct firmware versions are installed on each inverter. To save the information to a read-only file, tap the **PDF** icon (iOS) or the **JPEG** icon (Android) at the bottom of the screen.
2. Select **Status** and verify that inverter is operating and producing power.
3. Verify that additional configurations were properly set by viewing the relevant Status screens.
4. Verify that the green inverter LED is steadily lit.

Your SolarEdge power harvesting system is now operational.

### Reporting and Monitoring Installation Data

Monitoring the site requires connecting the inverter to the monitoring platform, using any of the wired or wireless options available from SolarEdge. Refer to *Setting Up Communication with the Monitoring Platform* on page 37.

## The Monitoring Platform

The monitoring platform provides enhanced PV performance monitoring and inverter yield assurance through immediate fault detection and alerts at the module, PV array and system level.

Using the platform, you can:

- View the latest performance of specific components.
- Find under-performing components, such as modules, by comparing their performance to that of other components of the same type.
- Pinpoint the location of alerted components using the physical layout.

The monitoring platform enables accessing site information, including up-to-date information viewed in a physical or logical view:

- **Logical Layout:** Shows a schematic tree-layout of the components in the system, such as: inverters, Power Optimisers, PV arrays, modules, meters and sensors, as well as their electrical connectivity. This view enables you to see which modules are

connected in each PV array, which PV arrays are connected to each inverter, and so on.

- **Physical Layout:** Provides a bird's eye view of the actual placement of modules in the site, and allows pinpoint issues to the exact location of each module on a virtual site map.

If you do not report the mapping of the installed Power Optimisers, the monitoring platform will show the logical layout, indicating which Power Optimisers are connected to which inverter, but will not show PV strings or the physical location of Power Optimisers.

The monitoring platform includes a built-in help system that guides you through the monitoring functionality.

For more information, refer to <https://www.solaredge.com/products/pv-monitoring#/>.



## Creating Logical and Physical Layout using Installation Information

To display a logical layout, insert in the new site created in the monitoring platform. When the communication between the and the monitoring server is established, the logical layout is displayed.

To display a physical layout, you need to map the locations of the installed power optimisers. To map the locations, use one of the methods described in the next sections.

### Designer

Designer recommends inverter and Power Optimiser selection per site size and enables report generation. You can create a project in Designer and export the site design with the PV array layout to the monitoring platform.

For more information, refer to

<https://www.solaredge.com/products/installer-tools/designer#/>.



## Physical Layout Editor

1. If you are a registered installer, access the monitoring platform site creation page at <https://monitoring.solaredge.com/solaredge-web/p/home#createSites>. If you have not yet signed up, go to <https://monitoring.solaredge.com/solaredge-web/p/createSelfNewInstaller>.
2. Fill out all required information in the screen, which includes information about your installation, as well as details about its logical and physical mapping.



## Signaling Options

### Alternative Power Source

Energy-generation systems (such as PV inverters) connected to the grid may consist of different types of energy generating sources.

In some cases, when grid power is disconnected, PV inverters operate in parallel with other voltage sources, such as generators.

When inverters operate concurrently with generators, they may be subjected to voltage and frequency fluctuations that exceed trips, which are preset according to regional grid connection requirements. To support simultaneous operation of the inverter and a generator, the inverter extends its Voltage and frequency operating range once it receives a Power Reduction Interface (PRI) signal indicating that grid power is unavailable ("Alternative Power Source mode"). When the grid power is restored, the inverter automatically reverts to its default country setting, which includes the original Voltage and frequency operating range.

Figure 31, shows an Example of Alternative Power Source System.

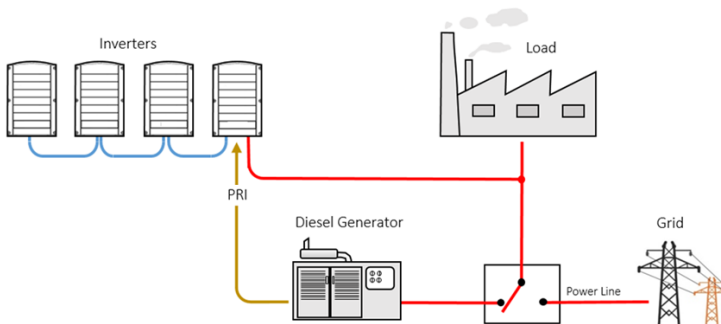
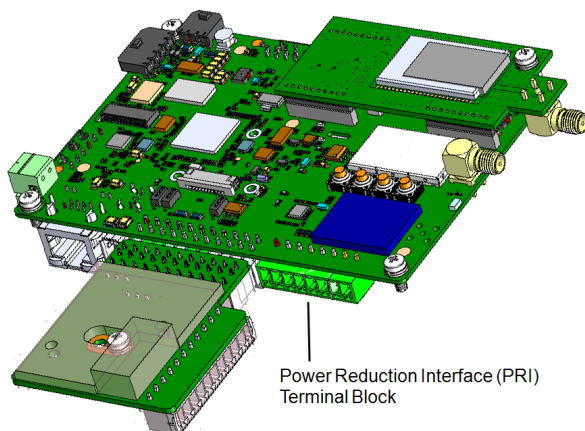

Figure 31: Example of Alternative Power Source System

The Power reduction Interface (PRI) terminal block on the communication board (See *Figure 32*) is used signaling the inverter to switch to Alternative Power Source mode.



Power Reduction Interface (PRI)  
Terminal Block

Figure 32: PRI Terminal Block Location on the Communication Board of the Inverter

For detailed connection and configuration of the inverter in alternative power source mode, refer to: <https://www.solaredge.com/sites/default/files/se-inverter-support-of-voltage-sources.pdf>

# Appendix A: Errors and Troubleshooting

This chapter describes how to troubleshoot general system problems. For further assistance, contact SolarEdge Support.

## Identifying Errors

Errors may be indicated in various system interfaces: On the inverter bottom panel, a red LED indicates an error. In the monitoring platform and SetApp, errors are displayed with codes.

For more information on the codes displayed for error and warning messages, refer to <http://www.solaredge.com/sites/default/files/se-inverter-installation-guide-error-codes.pdf>. This document describes errors that appear in SetApp, monitoring platform, and LCD (for inverters with LCD). To identify the error types, use the methods described below.

→ To identify the error type using the inverter LEDs:

1. Move the ON/OFF/P switch to **P** position for **2 seconds** and release it.
2. Observe the LED lights and use the following table to identify the error type. For more information, refer to:

<https://www.solaredge.com/leds>



Error Type	Inverter LED Color and State		
	Red	Green	Blue
Isolation or RCD problem	Blinking	OFF	OFF
Grid error	OFF	ON	OFF
High temperature	OFF	Blinking	OFF
Pairing failed	OFF	OFF	ON
Other issue	OFF	OFF	Blinking

→ To identify the error type using the monitoring platform:

1. Open the site dashboard and click the **Layout** icon.
2. Right-click the inverter and select **Info** from the menu. The inverter details window is displayed.
3. Click the **Errors** tab. The list is displayed.

## Troubleshooting Communication

### Troubleshooting Ethernet (LAN) Communication

The possible errors and their troubleshooting are detailed in the following table:

Error Message	Possible Cause and Troubleshooting
LAN cable disconnected	Physical connection fault. Check the cable pin-out assignment and cable connection.
No DHCP	IP settings issue. Check the router and configuration. Consult your network IT.
Configure Static IP or set to DHCP	
Gateway not responding	Ping to router failed. Check the physical connection to the switch/ router. Check that the link LED at the router /switch is lit (indicating phy-link). If OK - contact your network IT, otherwise replace the cable or change it from cross to straight connection.
No Internet connection	Ping to google.com failed. Connect a laptop and check for internet connection. If internet access is unavailable, contact your IT admin or your internet provider.

### Troubleshooting RS485 Communication

- If the message **RS485 Leader Not Found** appears in the Status screen, check the connections to the leader device and fix if required.
- If after follower detection the number of followers displayed for the leader under **RS485-1 > Follower Detect** is lower than the actual number of followers, refer to the following application note to identify missing followers and troubleshoot connectivity problems:  
[https://www.solaredge.com/sites/default/files/troubleshooting\\_undetected\\_RS485\\_devices.pdf](https://www.solaredge.com/sites/default/files/troubleshooting_undetected_RS485_devices.pdf)

## Additional Troubleshooting

1. Check that the modem or hub/router is functioning properly.
2. Check that the connection to the internal connector on the communication board is properly done.
3. Check that the selected communication option is properly configured.
4. Use a method independent of the SolarEdge device to check whether the network and modem are operating properly. For example, connect a laptop to the Ethernet router and connect to the Internet.
5. Check whether a firewall or another type of network filter is blocking communication.

## Power Optimiser Troubleshooting

Malfunction	Possible Cause and Corrective Action
Pairing failed	<p>Power Optimisers are shaded.</p> <p>If you connected the inverter to the monitoring platform, retry pairing remotely (during sunlight). Make sure to leave the inverter ON/OFF/P switch ON and that S_OK appears in the status screen.</p>
PV string Voltage is 0V	<p>Power Optimiser (s) output is disconnected.</p> <p>Connect all Power Optimiser outputs.</p>
PV string voltage not 0V but lower than number of Power Optimisers	<p>Power Optimiser(s) not connected in the PV string.</p> <p>Connect all Power Optimisers.</p>
	<p>Panel(s) not connected properly to Power Optimiser inputs (not applicable to smart modules).</p> <p>Connect the modules to the Power Optimiser inputs.</p>
	<p>PV string reverse polarity.</p> <p>Check PV string polarity using a voltmeter and correct if needed.</p>

Malfunction	Possible Cause and Corrective Action
<p>PV string Voltage is higher than number of Power Optimisers</p> <p><b>WARNING!</b> If the measured voltage is too high, the installation may not have a safe low voltage. <b>PROCEED WITH CARE!</b> A deviation of <math>\pm 1\%</math> per PV string is reasonable.</p> 	<p>Extra Power Optimiser(s) connected in the PV string (not applicable to smart modules). Check if an extra Power Optimiser is connected in the PV string. If not – proceed to next solution.</p> <p>A module is connected directly to the PV string, without a Power Optimiser (not applicable to smart modules). Verify that only Power Optimisers are connected in the PV string and that no module outputs are connected without a Power Optimiser. If the problem persists, proceed to the next step.</p> <p>Power Optimiser(s) malfunction.</p> <ol style="list-style-type: none"> <li>1. Disconnect the wires connecting the Power Optimisers in the PV string.</li> <li>2. Measure the output voltage of each Power Optimiser to locate the Power Optimiser that does not output 1V safety Voltage. If a malfunctioning Power Optimisers located, check its connections, polarity, module, and Voltage.</li> <li>3. Contact SolarEdge Support. Do not continue before finding the problem and replacing the malfunctioning Power Optimiser. If a malfunction cannot be bypassed or resolved, skip the malfunctioning Power Optimiser, thus connecting a shorter PV string.</li> </ol>

## Appendix B: Adding Optional Components

### AC Surge Protection Device (SPD)

The AC SPD is a device designed to protect the inverter from Voltage spikes and surge attempts forming on the AC grid lines. The SPD limits the Voltage supplied to the inverter by either blocking or shorting to ground Voltages above a safe threshold. The SPD is installed inside the inverter and communicates with the SolarEdge Monitoring platform for reporting surge protection events and faults.

For installation and configuration of AC SPD, refer to:

<https://www.solaredge.com/sites/default/files/se-ac-surge-protection-device-installation-guide.pdf>

### DC Surge Protection Device (SPD)

The DC SPD is a device designed to protect the inverter from Voltage spikes and surge attempts forming on the DC lines of the PV strings. The SPD limits the Voltage supplied to the inverter by either blocking or shorting to ground Voltages above a safe threshold. The SPD is installed inside the inverter and communicates with the SolarEdge Monitoring platform for reporting surge protection events and faults.

<https://www.solaredge.com/sites/default/files/se-dc-surge-protection-device-installation-guide.pdf>

# Appendix C: Mechanical Specifications

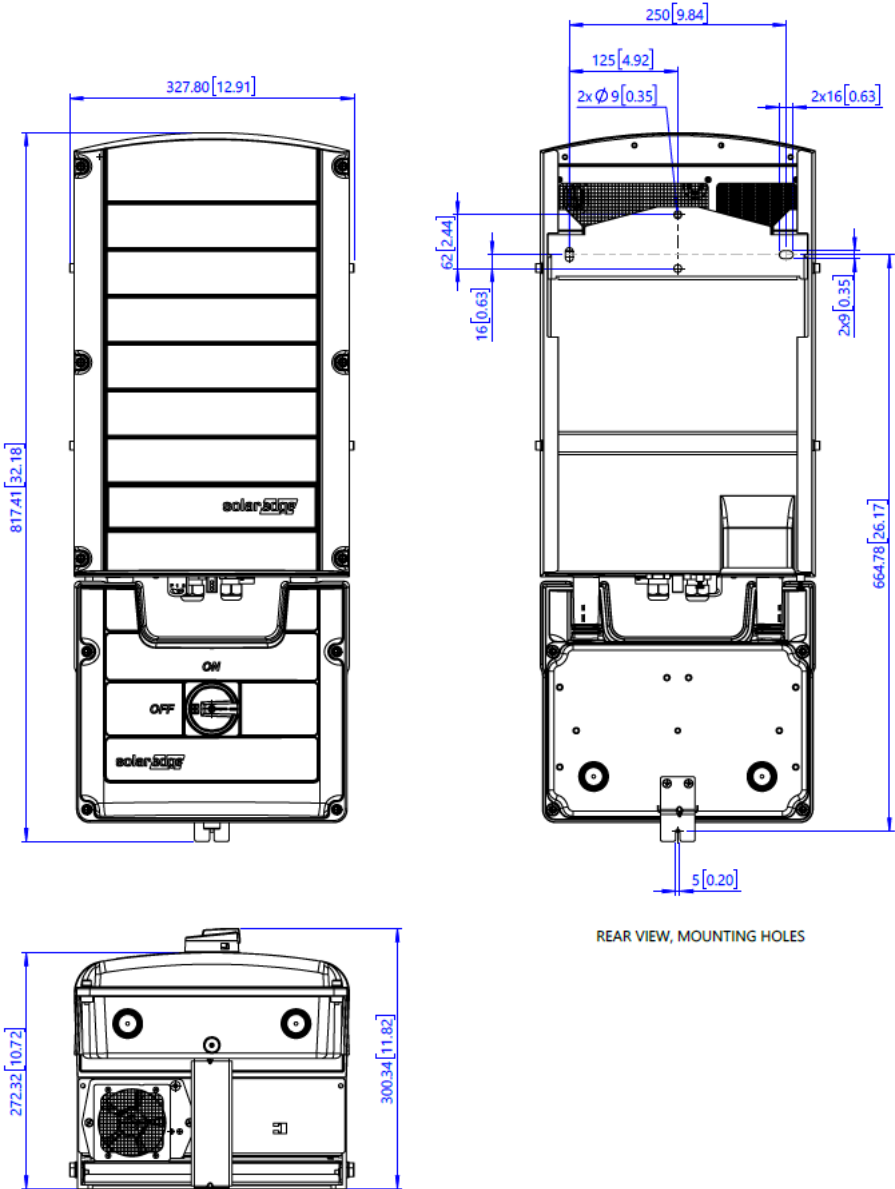

Figure 33: Dimensions of Three Phase Inverter with DC Safety Unit

## Dimensions of Inverter Mounting Bracket

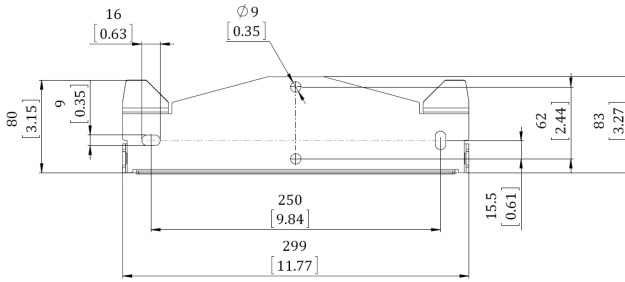

Figure 34: Dimensions of Inverter mounting bracket

## Support Contact Information

If you have technical problems concerning SolarEdge products, please contact us:



Before contact, make sure to have the following information at hand:

- Model and serial number of the product in question.
- The error indicated on the SetApp mobile application, on the monitoring platform, or by the LEDs, if there is such an indication.
- System configuration information, including the type and number of modules connected and the number and length of strings.
- The communication method to the SolarEdge server, if the site is connected.
- The product's software version as it appears in the status screen.

**solar**edge