



SolarEdge TerraMax™ Inverter

Quick Installation Guide

For Europe, APAC,
and South Africa
Version 1.7

Scan for full Installation Guide



Legend



NOTE

This symbol denotes information intended to assist the user in making optimum use of the product.



CAUTION!

Denotes a hazard. It calls attention to a procedure that, if not correctly performed or adhered to, could result in damage or destruction of the product. Do not proceed beyond a caution sign until the indicated conditions are fully understood and met.



WARNING!

Denotes a hazard. It calls attention to a procedure that, if not correctly performed or adhered to, could result in injury or loss of life. Do not proceed beyond a warning note until the indicated conditions are fully understood and met.



Do not cut the cable connectors



Do not bend the cable. Bending radius: 4 x wire diameter.



This symbol appears at grounding points on the SolarEdge manuals and equipment.

SAVE THESE INSTRUCTIONS – This guide contains important instructions for SolarEdge TerraMax Inverter that should be followed during installation and maintenance. Using this equipment in a manner not specified in this guide by SolarEdge may impair the protection provided by this equipment.

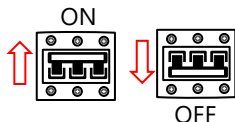

Turn ON/OFF the main circuit board AC switch. When turning it off, wait 5 minutes for DC Voltage to drop to a safe level before removing the front panel.

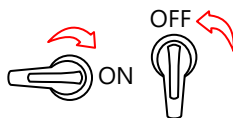

Turn the DC Disconnect Switch on/off. (Switch is available for some models) When turning it off, wait 5 minutes for DC Voltage to drop to a safe level before removing the front panel.

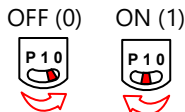

Turn the ON/OFF/P Switch on/off. When turning it off, wait 5 minutes for DC Voltage to drop to a safe level before removing the front panel.



Before connecting aluminum wires to terminals:

1. Remove oxide from the exposed wires with emery paper or a steel wire brush
2. Clean dust with a cloth and Isopropyl alcohol (IPA)
3. Coat wires with a designated antioxidant aluminum wire grease immediately after cleaning



CAUTION! Connection of oxidized aluminum wires may result in resistance and high temperatures at contact points. Improper execution of the following procedure may cause damage to the unit.



Before installation, read the **HANDLING AND SAFETY INSTRUCTIONS**



Installing the Power Optimizers

1

① → ② → ③ → ④ → ⑤ → ⑥

①

Use SolarEdge Designer to create and design SE system
<https://designer.solaredge.com>

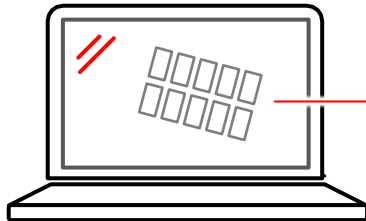

②

Create a new site in Monitoring Platform and import PV layout from SolarEdge Designer
<https://monitoring.solaredge.com/solaredge-web/p/login>

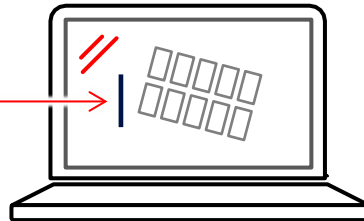

③

Download SolarEdge Mapper to map string Power Optimizers



1

Installing the Power Optimizers

① → ② → ③ → ④ → ⑤ → ⑥

④

Install the H1300 Power Optimizer

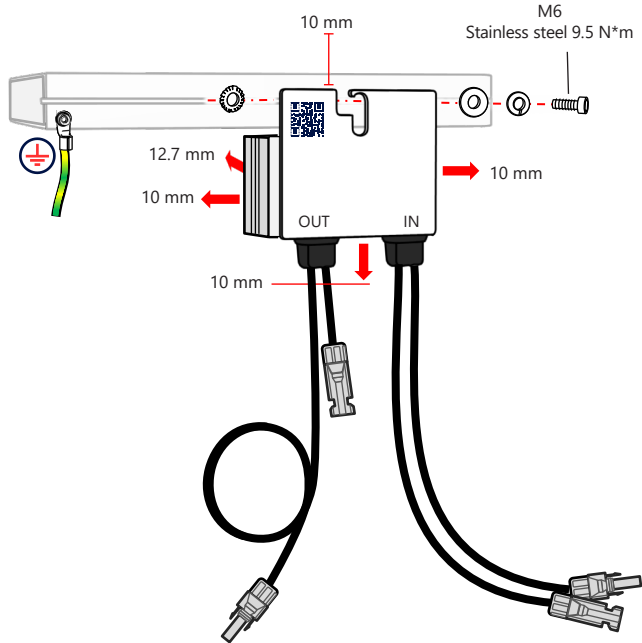

⑤

Scan QR code using Mapper

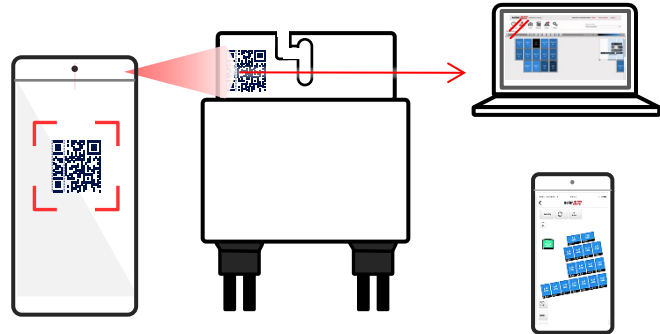

Connecting the Power Optimizers

1

① → ② → ③ → ④ → ⑤ → ⑥



CAUTION! Do not sharply bend the DC cables. Keep proper bending radius to avoid cable break. Do not use stretched cabling. Using only MC4 connectors compatible with the Power optimizer.

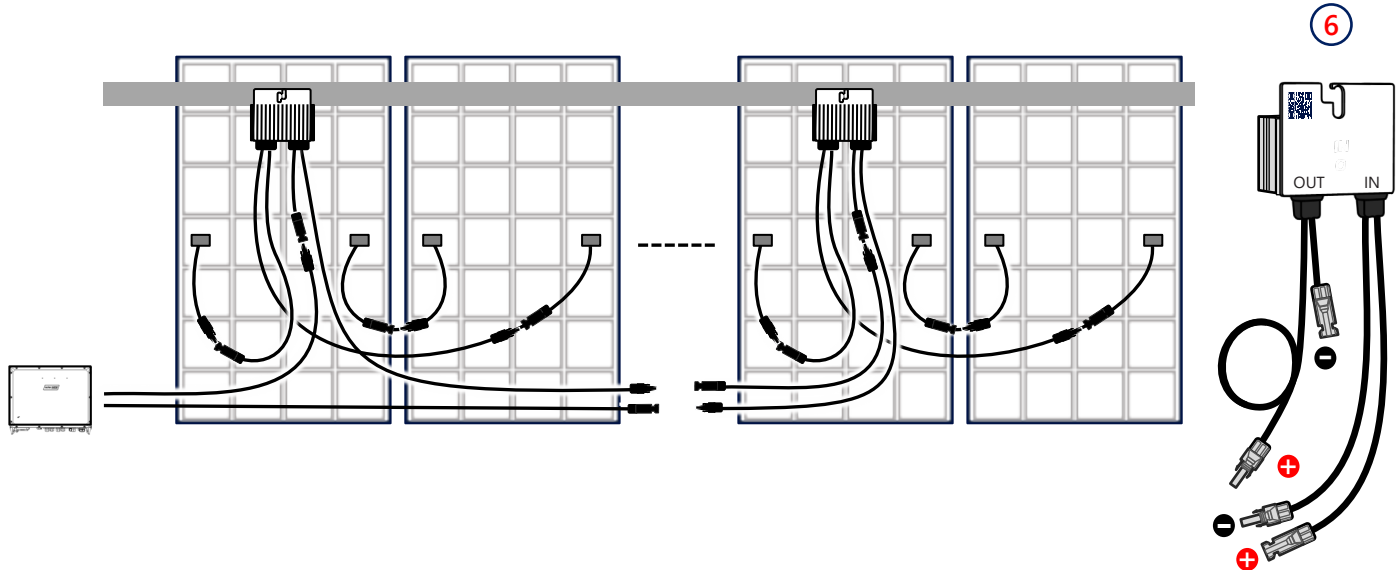

2 Connecting PV Strings

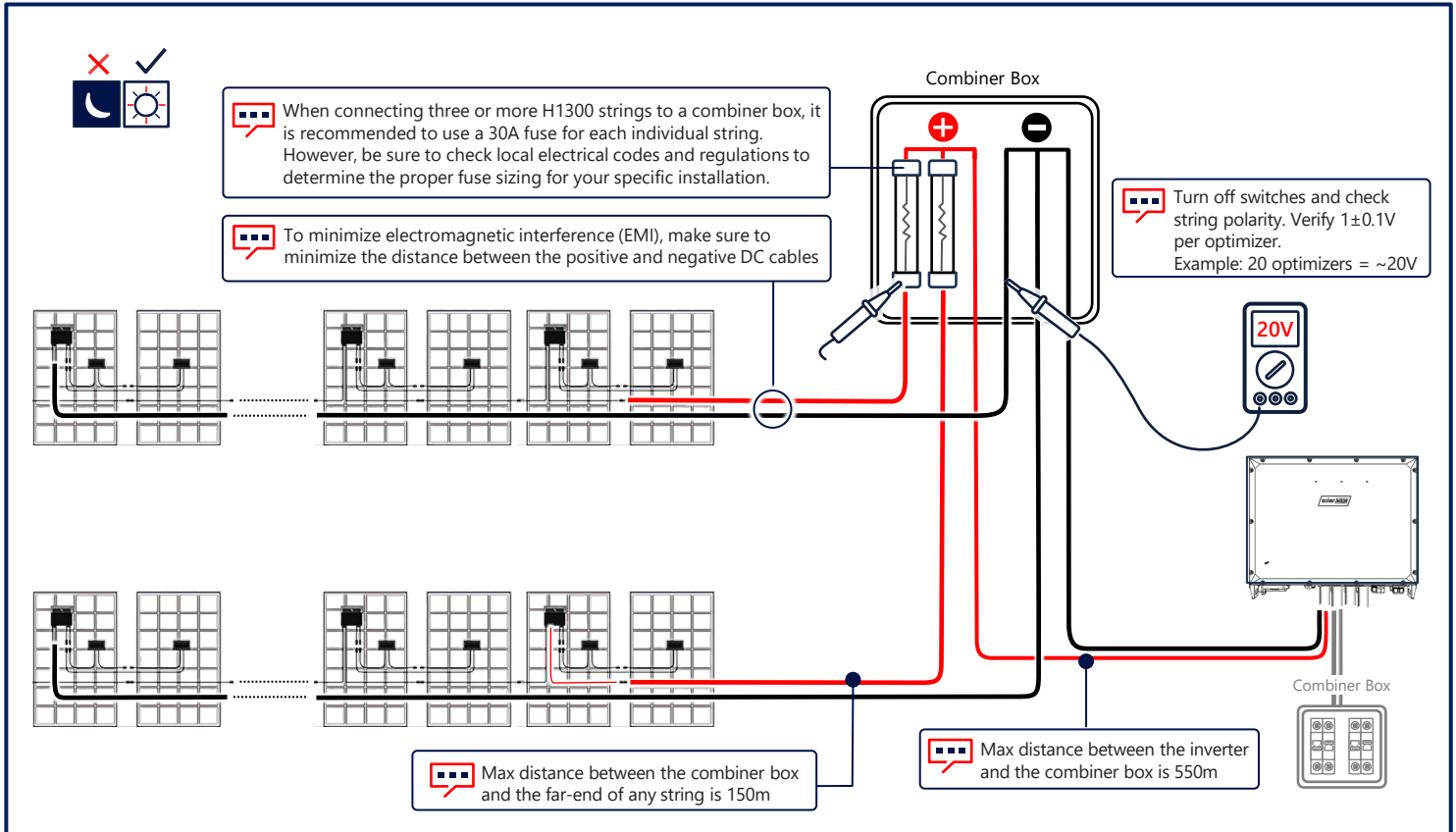

Maintaining Clearance

3

Min Side By Side Clearance

500 mm, 1000 mm, 500 mm, 500 mm

CAUTION! Install more than 50 m from a saline environment

It is recommended to avoid direct sun light

CAUTION! By installing the inverters on a centralized platform, all clearances must be followed. Vertical installation of inverters (one above the other) is prohibited

WARNING! The area in front of the inverter must be kept clear for at least 915 mm

CAUTION! Do not block Airflow

416 mm, 915 mm, 400 mm

Back-to-back Clearance

4 Mounting

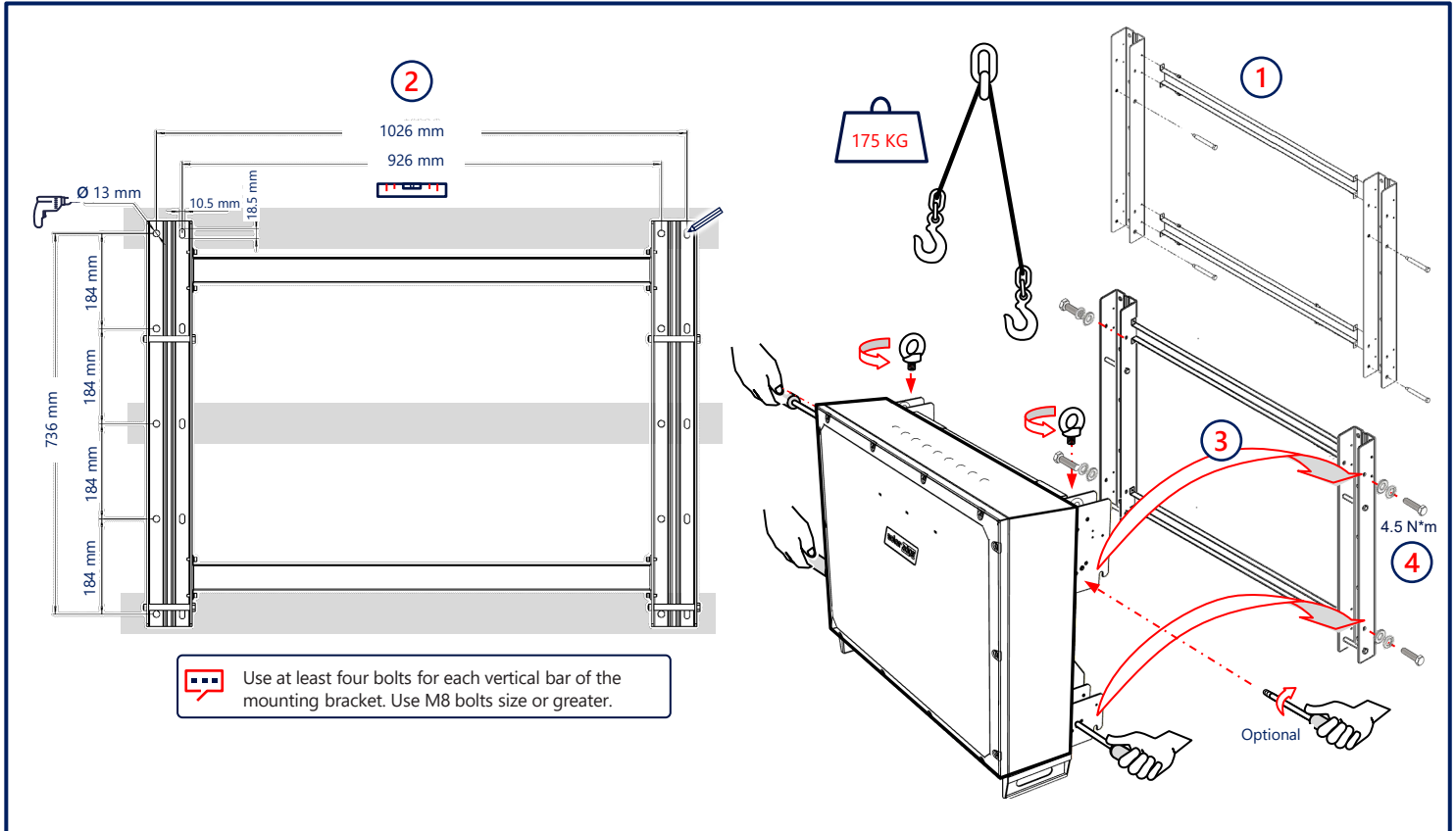

Connecting Chassis and Ground Removing Covers

5



WARNING

DISCONNECT POWER AND WAIT 5 MINUTES BEFORE REMOVING COVERS



OFF (0)



OFF

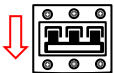

OFF

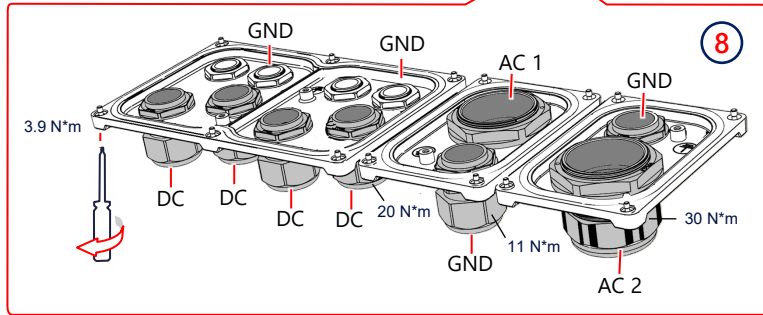
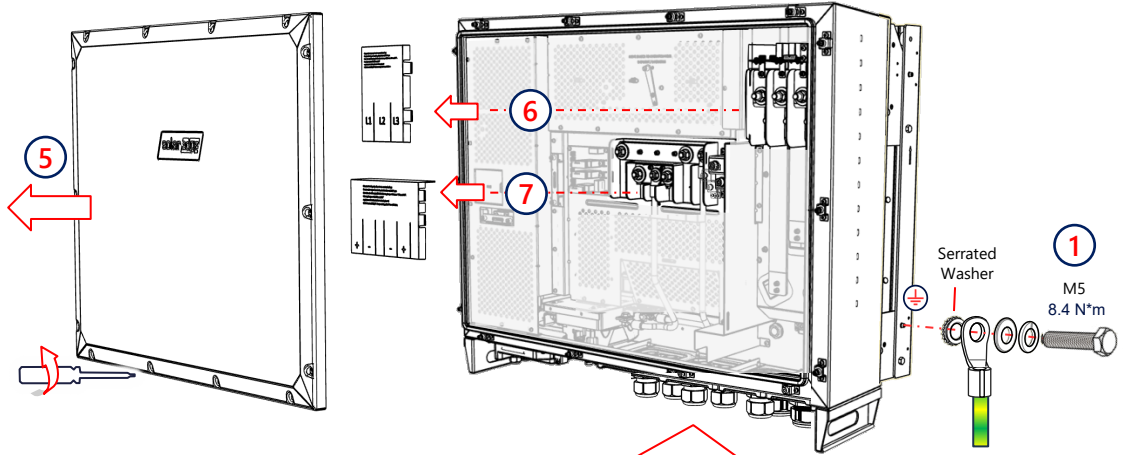

6 Connecting the PV Arrays

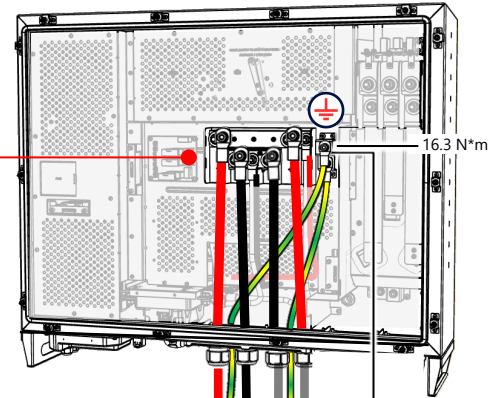
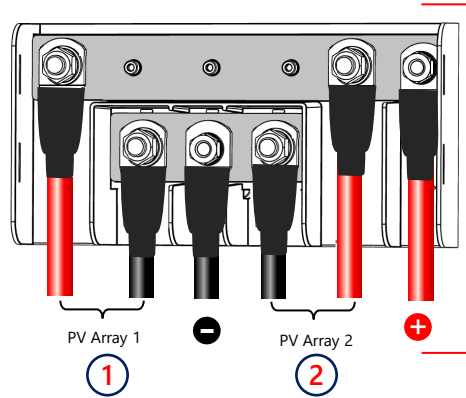
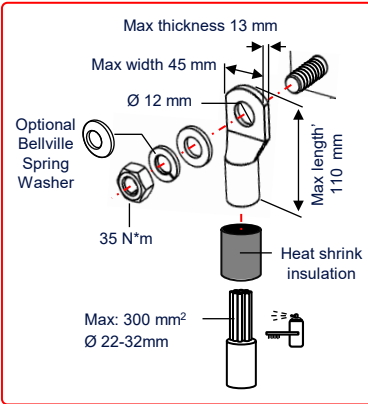

⚠ CAUTION!

- For aluminum cables: Use Al/Cu (bi-metal) lugs or aluminum lugs with bi-metal washers. Place the bi-metal washer between the aluminum lug and the inverter bus bar, copper side facing the bus bar.
- For copper cables: Use only copper tin-plated lugs.

☞ One-hole, standard barrel, compression lugs only

☞ Use AC cables with 90°C Cu / Al wires
 Use outdoor copper core PE wires

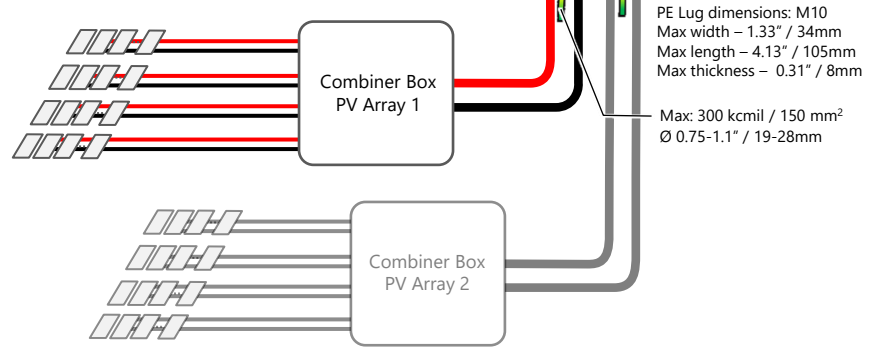

Connecting AC and Protective Earth (PE)

7

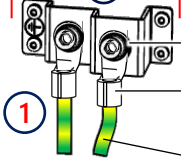
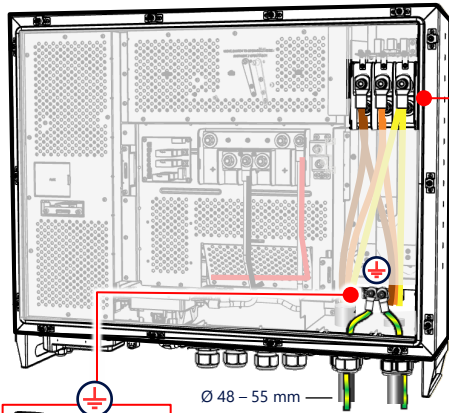

Yellow/Green

Ø 48 – 55 mm

16.3 N*m

PE Lug dimensions: M10

Max width – 34 mm

Max length – 105 mm

Max thickness – 8 mm

Max: 150 mm²

Ø 19-28 mm

CAUTION! First, connect the Protective Earth (PE) wire

Use AC cables with 90°C Cu / Al wires
Use outdoor copper core PE wires

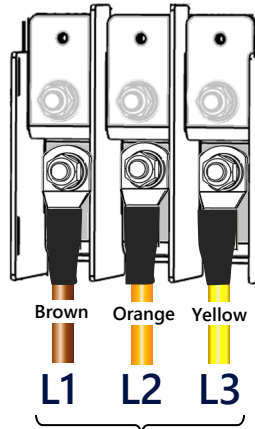

Brown

Orange

Yellow

L1

L2

L3

Ø 1

2

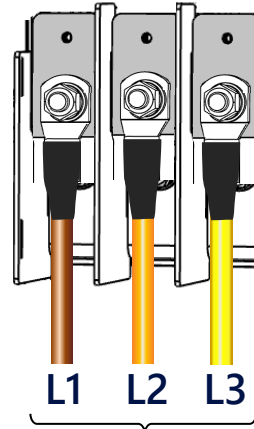

L1

L2

L3

Ø 2

3



Overcurrent protection for the AC output must be provided by others. See full installation guide for guidance

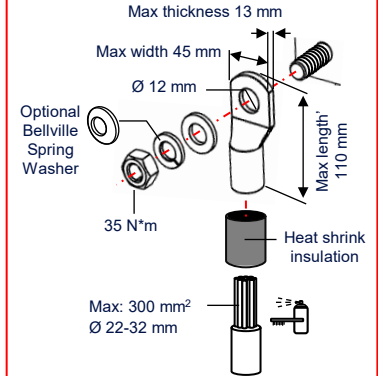

CAUTION!

- For aluminum cables: Use Al/Cu (bi-metal) lugs or aluminum lugs with bi-metal washers. Place the bi-metal washer between the aluminum lug and the inverter bus bar, copper side facing the bus bar.
- For copper cables: Use only copper tin-plated lugs.



One-hole, standard barrel, compression lugs only

8

Accessing the Communication Compartment

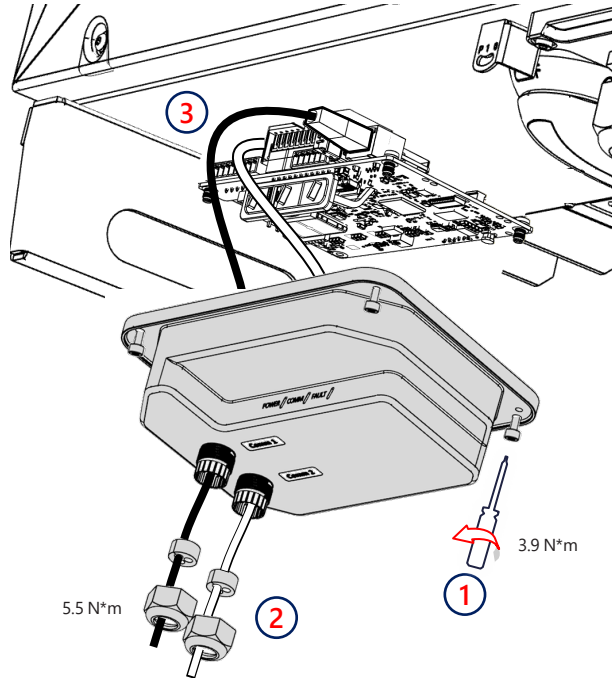

Connecting Communication

9

CAN Bus (for connection between inverters)

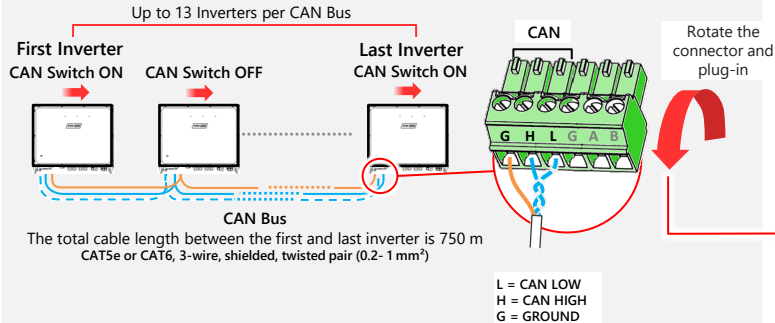

IMPORTANT! DO NOT connect inverters other than SolarEdge TerraMax Inverters.

IMPORTANT! Move the CAN Switch of the first and last inverters on the bus to ON position.

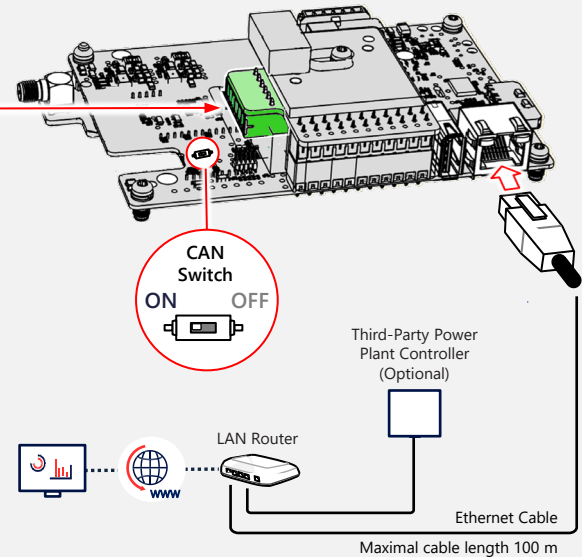

RS-485 Bus (for connecting third-party devices such as meter or PPC)

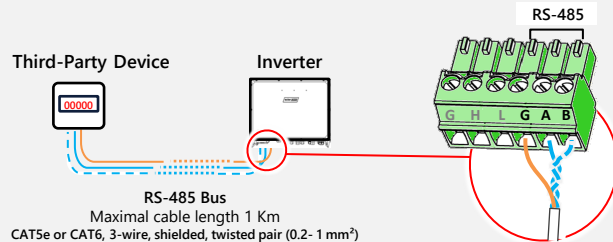

10 Unlocking Relays and Installing the Covers

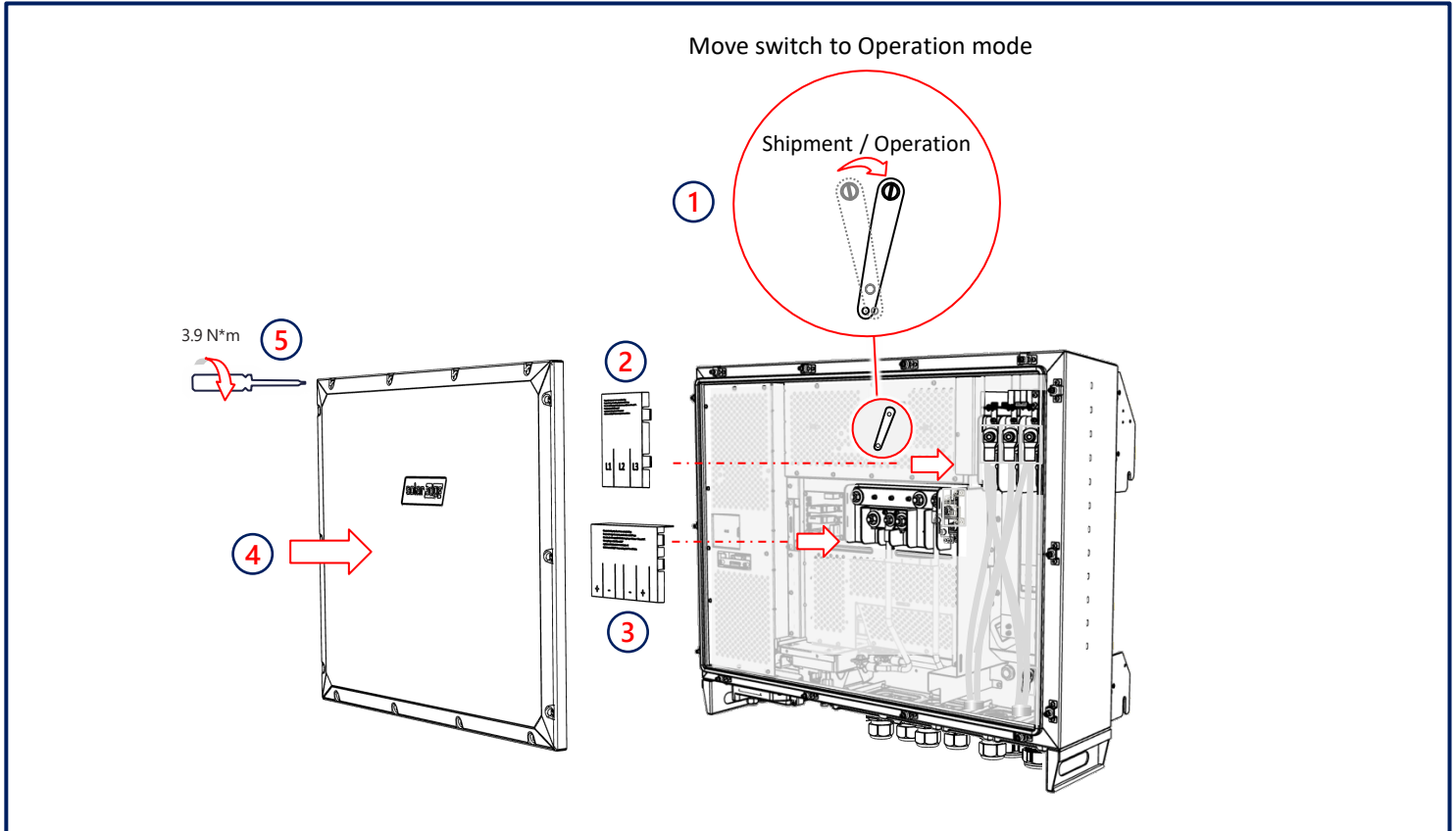

Commissioning (Part 1)

11

1
Download
SolarEdge SetApp

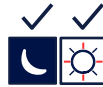

Commissioning when connected to AC from Grid



Commissioning when connected only to DC from PV Array

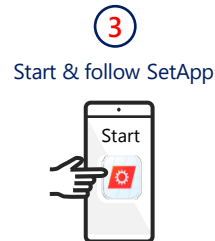

12

Commissioning (Part 2)

① Country & Grid

② Pairing

③ Site Communication

Site Communication

Power Control

Grid Protection

⑤ Central Commissioning

Maintenance

Information

④ Status

CAN → Protocol → SolarEdge → **SolarEdge Leader**

CAN → Protocol → SolarEdge → **Follower Detect**

Tap to simultaneously commission all Follower Inverters

Grid Monitoring Completed.

solar_{edge}
SN E7548404-0E

Production 51.68 kW	Limit 660 kW	Inverters 2 of 2
Inverter SN 7D00006C-E9		
Summary		
Active Power 51.68 kW	Apparent Power 51.85 kVA	Reactive Power -4.18 kVAR
I1 41.76 Aac	I2 41.92 Aac	I3 41.91 Aac
V12 709 Vac	V23 714 Vac	V31 714 Vac
P_OK: 47 of 47 Optimizers Communicating	Server Comm. S_OK Ethernet	
Status Production	Power Limit 330 kW	Switch is On
Cos Phi 1	Frequency 50 Hz	Country Germany 690LL
DC Power 52.47 kW	DC Voltage 1.26 kVdc	DC Current 41.73 Adc



For detailed Status and System
Performance LED Indications:
<https://www.solaredge.com/leds>

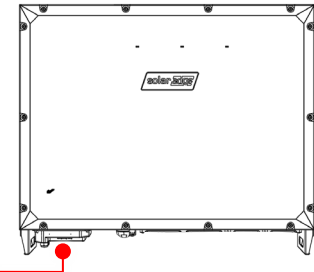
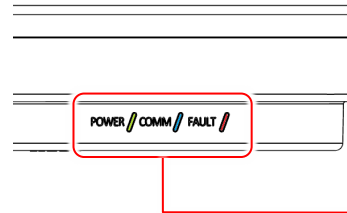

POWER COMM FAULT

Green Blue Red



System is producing Power



AC is connected but the system is not producing power



Inverter is communicating with the Monitoring platform



System error



Support Contact Information

If you have technical problems concerning SolarEdge products, please contact us:

<https://www.solaredge.com/service/support>

Subject to change without notice.

Copyright © SolarEdge Inc.

All rights reserved. January 2025.



MAN-01-01066-1.7