



Installation Guide

SolarEdge Home Hub Inverter Single Phase for North America

Version 1.9

February 2026

Table Of Contents

Disclaimers	1
Important Notice	1
FCC compliance	2
Revision history	2
Handling and safety instructions	2
Safety symbols information	2
Important safety instructions	3
CONSIGNES DE SÉCURITÉ IMPORTANTES	3
Photovoltaic rapid shutdown system requirements	9
Overview	10
StorEdge solution components	10
Supported batteries	10
Installation equipment list	11
Inverter transport and storage	12
Safety	13
SolarEdge Power Control System	15
Supporting inverters	16
PCS certification training	16
Activate busbar current management	16
Installation guidelines	16
Using an extension cable between a Power Optimizer and a PV module	17
For S-Series Commercial Power Optimizers with part numbers in the format S1xx-1xxxxxx:	17
For P-Series Power Optimizers with the 4-type suffix in their part number (Pxxx-4xxxxxx) and for the Mxxxx-Series:	17
For S-Series Residential Power Optimizers, and P-Series Residential Power Optimizers with the 5-type suffix in their part number (Pxxx-5xxxxxx):	17
Using Extension Cables Between two Power Optimizers or between a Power Optimizer and the Inverter	17
Installing Power Optimizers	17
Mounting the Power Optimizers	18
Grounding the Power Optimizers	19
Mounting the Power Optimizers on a grounded metal rail	19
Mounting Power Optimizers on rails with sliding nut fasteners:	20
Mounting Power Optimizers on ungrounded structures	20
Completing the Power Optimizer installation	21
Connecting a PV panel to a Power Optimizer	21
Connecting Power Optimizers in strings	22
Verifying correct Power Optimizer connection	23
Installing the inverter	24
Inverter package contents	24
Identifying the inverter	24

- Inverter interfaces 24
- Mounting the inverter 28
 - Installing the mounting bracket 30
 - Hanging the inverter on the bracket: 30
 - Attaching the connection unit bracket (optional) 31
 - To secure the connection unit bracket to the wall/pole: 31
- Selecting a Residual Current Device (RCD) 32
- Installing the battery (optional) 33
- Connecting the inverter 34
 - Installing conduits 34
 - Connecting the inverter to the AC grid 34
 - Connecting the DC strings to the inverter 35
 - To connect the DC strings: 35
 - Connecting the battery (optional) 36
 - Connecting the Backup Interface 39
 - To connect the Backup Interface 39
 - Connecting the Smart EV Charger (Optional) 40
 - To connect the Smart EV Charger: 40
 - Connecting an external RSD switch 41
 - To connect an external RSD switch to an inverter 41
 - To connect an external RSD switch to multiple inverters: 42
 - Connecting multiple inverters via RS485 42
 - To connect an additional Home Hub inverter 43
 - To connect an additional HD-Wave inverter: 43
- Activating, commissioning and configuring the system 44
 - Activating the system 45
 - Before activation 45
 - To activate the inverter 45
 - Commissioning the system 45
 - Power Control 46
 - Verifying activation and commissioning 46
 - To verify correct activation and commissioning 46
 - Configuring communication with other devices 46
 - To set up communication with an external Energy Meter 46
 - To set up communication with the Smart EV Charger 47
- Enabling StorEdge applications 47
 - Backup Power applications 47
 - To enable Backup Configuration 48
 - To enable a StorEdge application 48
- Reporting and monitoring installation data 48
 - The Monitoring platform 48
 - Creating Logical and Physical layout using installation information 49
 - Designer 49
 - Mapper Application 49
 - Physical Layout Editor 50
- Setting up communication with the Monitoring platform 50

Communication options	51
Ethernet	51
RS485	51
Wireless Gateway, Wireless Repeater/s	51
Cellular	52
Communication connectors	52
Removing the inverter cover	53
To remove the inverter cover	53
Removing the Connection Unit cover	53
Creating an Ethernet (LAN) connection	53
To connect the Ethernet cable	54
Verifying the connection	56
Appendix A: Errors and troubleshooting	57
Identifying errors	57
To identify the error type using the inverter LEDs:	57
To identify the error type using the monitoring platform:	57
Home Hub Inverter troubleshooting	58
Troubleshooting Communication	59
Troubleshooting Ethernet (LAN) Communication	59
Troubleshooting RS485 communication	59
Additional troubleshooting	59
Power Optimizer troubleshooting	60
Support contact information	61
Appendix B: UL 9540 Multi-part ESS components	62

Disclaimers

Important notice

Copyright © SolarEdge Inc. All rights reserved.

No part of this document may be reproduced, stored in a retrieval system or transmitted, in any form or by any means, electronic, mechanical, photographic, magnetic or otherwise, without the prior written permission of SolarEdge Inc.

The material furnished in this document is believed to be accurate and reliable. However, SolarEdge assumes no responsibility for the use of this material. SolarEdge reserves the right to make changes to the material at any time and without notice. You may refer to the SolarEdge web site (<https://www.solaredge.com/us/>) for the most updated version. All company and brand products and service names are trademarks or registered trademarks of their respective holders.

Patent marking notice: see <https://www.solaredge.com/us/patent>

The general terms and conditions of delivery of SolarEdge shall apply. The content of these documents is continually reviewed and amended, where necessary. However, discrepancies cannot be excluded. No guarantee is made for the completeness of these documents. The images contained in this document are for illustrative purposes only and may vary depending on product models.

Important Notice

Copyright © SolarEdge Inc. All rights reserved.

- No part of this document may be reproduced, stored in a retrieval system or transmitted, in any form or by any means, electronic, mechanical, photographic, magnetic or otherwise, without the prior written permission of SolarEdge Inc.
- The material furnished in this document is believed to be accurate and reliable. However, SolarEdge assumes no responsibility for the use of this material. SolarEdge reserves the right to make changes to the material at any time and without notice. You may refer to the SolarEdge web site (<https://www.solaredge.com/us/>) for the most updated version.
- All company and brand products and service names are trademarks or registered trademarks of their respective holders.
- Patent marking notice: see <https://www.solaredge.com/us/patent>.
- The general terms and conditions of delivery of SolarEdge shall apply.
- The content of these documents is continually reviewed and amended, where necessary. However, discrepancies cannot be excluded. No guarantee is made for the completeness of these documents.
- The images contained in this document are for illustrative purposes only and may vary depending on product models.

FCC compliance

This equipment has been tested and found to comply with the limits for a Class B digital device, pursuant to part 15 of the FCC Rules.

These limits are designed to provide reasonable protection against harmful interference. This equipment generates, uses and can radiate radio frequency energy and, if not installed and used in accordance with the instructions, may cause harmful interference to radio communications. However, there is no guarantee that interference will not occur in a particular installation.

If this equipment does cause harmful interference to radio or television reception, which can be determined by turning the equipment off and on, you are encouraged to try to correct the interference by one or more of the following measures:

- Reorient or relocate the receiving antenna.
- Increase the separation between the equipment and the receiver.
- Connect the equipment into an outlet on a circuit different from that to which the receiver is connected.
- Consult the dealer or an experienced radio/TV technician for help.

Changes or modifications not expressly approved by the party responsible for compliance may void the user's authority to operate the equipment.

Revision history

Version	Date	Description
1.9	February 2026	General updates. Added models to Appendix B. Removed LG Chem from table. Revised Energy Storage Systems and Equipment information.
1.8	July 2024	Added note regarding grounding of Power Optimizers
1.7	July 2024	Added information on the Power Control System

Handling and safety instructions

Safety symbols information

The following safety symbols are used in this document. Familiarize yourself with the symbols and their meaning before installing or operating the system.

**WARNING**

Denotes a hazard. It calls attention to a procedure that, if not correctly performed or adhered to, could result in injury or loss of life. Do not proceed beyond a warning note until the indicated conditions are fully understood and met.

AVERTISSEMENT!

Dénote un risque: il attire l'attention sur une opération qui, si elle n'est pas faite ou suivie correctement, pourrait causer des blessures ou un danger de mort. Ne pas dépasser une telle note avant que les conditions requises soient totalement comprises et accomplies

**CAUTION**

Denotes a hazard. It calls attention to a procedure that, if not correctly performed or adhered to, could result in damage or destruction of the product. Do not proceed beyond a caution sign until the indicated conditions are fully understood and met.

ATTENTION!

Dénote un risque: il attire l'attention sur une opération qui, si elle n'est pas faite ou suivie correctement, pourrait causer un dommage ou destruction de l'équipement. Ne pas dépasser une telle note avant que les conditions requises soient totalement comprises et accomplies.

**NOTE**

Denotes additional information about the current subject.

**IMPORTANT**

IMPORTANT SAFETY FEATURE

Denotes information about safety issues.

Important safety instructions

SAVE THESE INSTRUCTIONS

CONSIGNES DE SÉCURITÉ IMPORTANTES

CONSERVEZ CES INSTRUCTIONS

**WARNING**

To reduce the risk of injury, read all instructions in this document.

AVERTISSEMENT!

Pour réduire le risque de blessure, lisez toutes les instructions de ce document.

**WARNING**

Before opening the inverter cover:

1. Turn off the inverter ON/OFF/P switch located at the bottom of the inverter.
2. Turn off the Connection Unit DC safety switch.
3. Turn off the inverter AC circuit breaker on the main service panel.
4. Wait five minutes for the capacitors to discharge.

**WARNING**

AVERTISSEMENT!

1. *Eteignez l'onduleur à l'aide sur commutateur ON/OFF/P sur OFF=0.*
2. *Eteignez le sectionneur DC (si applicable).*
3. *Eteignez le disjoncteur AC de l'onduleur dans le tableau général.*
4. *Attendez 5 minutes pour la décharge des capacités.*

**WARNING**

Before operating the inverter, ensure that the inverter is grounded properly. This product must be connected to a grounded, metal, permanent wiring system, or an equipment-grounding conductor must be run with the circuit conductors and connected to the equipment grounding terminal or lead on the product.

AVERTISSEMENT!

Avant d'utiliser l'onduleur monophasé, assurez-vous que l'onduleur est correctement mis à la terre. Ce produit doit être raccordé à un système de câblage fixe, métallique, l'équipement-le conducteur de mise à la terre doit être exécuté avec les conducteurs de circuit et raccordé à l'équipement borne de mise à la terre ou de plomb sur le produit

**WARNING**

Opening the inverter and repairing or testing under power must be performed only by qualified service personnel familiar with this inverter.

AVERTISSEMENT!

**WARNING**

The Connection Unit meets all requirements for a code-compliant installation of this system. The DC Disconnect Switch disconnects both the positive and negative conductors.

AVERTISSEMENT!

Le sectionneur externe (inclus) répond aux exigences de conformité pour l'installation de ce système . Le coupeur CC ouvre les conducteurs positifs et négatifs.

**WARNING**

The inverter input and output circuits are isolated from the enclosure. This system does not include an isolation transformer and should be installed with an ungrounded PV array in accordance with the requirements of NEC Articles 690.35 and 690.43 National Electric Code, ANSI/NFPA 70, 2011 (and Canadian Electrical Code, Part I, for installations in Canada). Equipment grounding is the responsibility of the installer and must be performed in accordance with all applicable Local and National Codes.

AVERTISSEMENT!

Les circuits d'entrée et de sortie de l'onduleur sont isolés de l'enveloppe. Ce système n'inclut pas d'isolation galvanique (transformateur) et devra être installé sans mise à la terre du champ PV et en accord avec les articles 690.35 et 690.43 du National Electric Code (NEC), ANSI/NFPA 70, 2011 (et du Code Electrique Canadien, Partie 1, pour les installations faites au Canada). La mise à la terre des équipements est la responsabilité de l'installateur et doit être faite en accord avec les toutes les règles locales et nationales applicables.

**WARNING**

The inverter must be connected to a dedicated AC branch circuit with a maximum Overcurrent Protection Device (OCPD) as shown in the table below:

AVERTISSEMENT!

Les onduleurs doivent être connectés à un branchement AC dédié avec un disjoncteur comme décrit ci-dessous:

Part Number	USMNBbxxx	USMNBbxxx	USMNUxxx5	USMNFxxx5	USSKBEZ8
SE3800H-	50A		80A	80A	80A
SE5000H-					
SE5700H-					
SE6000H-					
SE7600H-	80A				
SE9600H-					
SE10000H-					
SE11400H-					



WARNING

SolarEdge products can expose you to chemicals including antimony trioxide, which is known to the State of California to cause cancer. For more information, go to www.P65Warnings.ca.gov

AVERTISSEMENT!

Les produits SolarEdge peut vous exposer à des agents chimiques, y compris trioxyde d'antimoine, identifiés par l'État de Californie comme pouvant causer le cancer. Pour de plus amples informations, prière de consulter www.P65Warnings.ca.gov



CAUTION

This unit must be operated according to the technical specification datasheet provided with the unit.

ATTENTION!

Cette unité doit être utilisée selon les spécifications de fonctionnement, comme décrit dans la dernière fiche technique des spécifications



CAUTION

HEAVY OBJECT. To avoid muscle strain or back injury, use proper lifting techniques, and if necessary, use a lifting aid.

ATTENTION!

Objet lourd. Pour éviter la fatigue musculaire ou des blessures au dos, utilisez des techniques de levage appropriées et, si nécessaire - un auxiliaire de levage lors du retrait

**NOTE**

The Connection Unit is NEMA type 3R rated . Unused conduit openings and glands should be sealed with appropriate seals.

Use only copper conductors rated for a minimum of 75°C/167°F.

This inverter is provided with an IMI (Isolation Monitor Interrupter) for ground fault protection.

The  symbol appears at grounding points on the SolarEdge equipment. This symbol is also used in this manual.

**WARNING**

Before operating the system, ensure that it has been properly grounded.

AVERTISSEMENT!

Avant d'utiliser l'onduleur monophasé, assurez-vous que l'onduleur est correctement mis à la terre.

**WARNING**

When handling the storage system battery, adhere to all manufacturer safety instructions.

AVERTISSEMENT!

Durant la manipulation de la batterie, adhérez à toutes les instructions de sécurité du fabricant.

**WARNING**

Before connecting the battery to the inverter, verify that the battery is powered off.

SolarEdge Home Battery

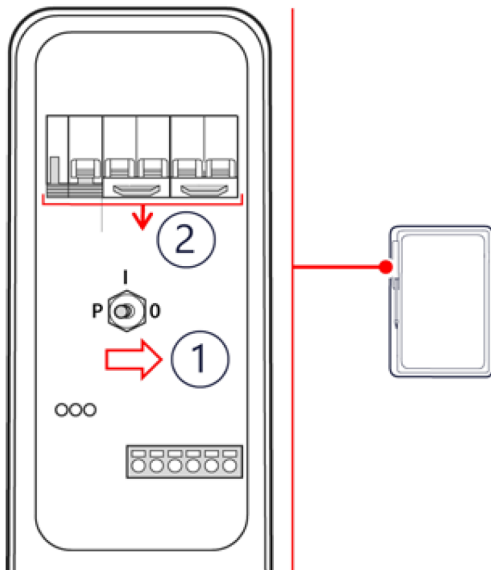

1. Toggle off the battery P/I/O switch.
2. Turn off the battery circuit breaker.



CAUTION

This unit must be operated under the specified operating conditions as described in the technical specifications supplied with the unit.

Cette unité doit être opérée suivant les instructions trouvées dans le manuel fourni avec le produit.



NOTE

The battery used must be NRTL certified.

For battery decommissioning and disposal, follow the manufacturer requirements and instructions.

For inverters with a nameplate rating up to and including 11.4W:

- Maximum short circuit peak current: 78.1A
- Maximum short circuit current duration (until current stops): 113msec
- Maximum 3-cycle short circuit current RMS value: 60A

Photovoltaic rapid shutdown system requirements



WARNING

THIS PHOTOVOLTAIC RAPID SHUTDOWN SYSTEM (PVRSS) INCORPORATES ONE OR MORE PIECES OF EQUIPMENT THAT EXERCISE THE RAPID SHUTDOWN CONTROL OF PV SYSTEM CONDUCTORS REQUIRED BY SECTION 690.12 OF THE NEC (NFPA 70). OTHER EQUIPMENT INSTALLED IN OR ON THIS PV SYSTEM MAY ADVERSELY AFFECT THE OPERATION OF THIS PVRSS. IT IS THE RESPONSIBILITY OF THE INSTALLER TO ENSURE THAT THE COMPLETED PV SYSTEM MEETS THE APPLICABLE RAPID SHUT DOWN FUNCTIONAL REQUIREMENTS. THIS EQUIPMENT MUST BE INSTALLED ACCORDING TO THE MANUFACTURER'S INSTALLATION INSTRUCTIONS.

- SolarEdge inverters and Power Optimizers installed together form a photovoltaic rapid shutdown system (PVRSS). All inputs and outputs of the inverter and Power Optimizers comply with photovoltaic rapid shutdown requirements for controlled conductors both inside and outside the PV array boundary. To form a PV rapid shutdown system, no more than 30 Power Optimizers should be installed in series. Each Power Optimizer will output around 1 Vdc when rapid shutdown is initiated. Rapid shutdown time limit is 30 Sec.
- This SolarEdge system is compatible with the **Grid support interactive compatible** functionality.
- All DC and AC conductors served by the Power Optimizers and inverters are controlled by the photovoltaic rapid shutdown system. The AC branch circuit conductors serving the inverter may remain energized until the AC service panel is de-energized. Installers must provide signage complying with Section 690.56(C) of the NEC (NFPA 70).
- Buildings with rapid shutdown PV systems, complying with NEC 690.56(C), shall have permanent labels as described in 690.56(C)(1) through (C)(2):

(1)(a) For PV systems that shut down the array and conductors leaving the array: The title "**SOLAR PV SYSTEM EQUIPPED WITH RAPID SHUTDOWN**" shall utilize capitalized characters with a minimum height of 3/8 in. in black on yellow background, and the remaining characters shall be capitalized with a minimum height of 3/16 in. in black on white background.

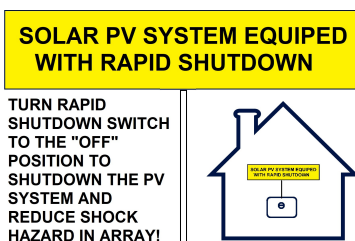

(2) A rapid shutdown switch shall have a label located on or no more than 3 ft from the switch that includes this wording. The label shall be reflective, with all letters capitalized and having a minimum height of 3/8 in., in white on red background.

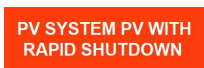

For instructions on connecting a rapid shutdown switch, see [Connecting an External RSD Switch](#) .

Overview

The single phase Home Hub inverter with prism technology is SolarEdge's all-in-one solution that uses a single phase DC optimized inverter to manage and monitor solar power generation, energy storage, EV charging and smart energy devices. When installed with a battery and the Backup Interface, homeowners are automatically provided with backup power in the event of grid interruption to power home loads. In addition, solar energy can be stored in a battery for Smart Energy Management applications such as export control, offering demand response and peak shaving, and performing time of use shifting for reduced electric bills.

StorEdge solution components

- **Home Hub inverter** - manages battery and system energy, in addition to its traditional functionality as a DC-optimized PV inverter.
- The **Connection Unit**, located at the bottom of the inverter, allows simple installation and connectivity to other system components and includes a DC Safety Switch.
- **One or multiple batteries (optional)** - DC-coupled batteries designed to work with the SolarEdge system. The batteries can be connected to the system optionally.
- See **Appendix B** for UL 9540 ESS components.

Supported batteries

Manufacturer	Model	Technical Description	Mark of Conformity
SolarEdge	Home Battery	Residential ESS (lithium ion battery)	UL 1973 / UL9540 / UL9540A / CE / RCM / (IEC 62619)

For the SolarEdge Home Battery installation guide refer to this [Installation Guide](#).



- **Backup Interface (optional, required for backup support)** - controls the disconnection of house loads from the grid and integrates the following components to enable grid-tied solar backup and Smart Energy Management. The Backup Interface must be installed to allow the operation of the batteries and inverter during backup.

- **Energy Meter** - is used by the inverter for export, import, production and consumption readings, and for Smart Energy Management applications, such as: export limitation, time-of-use profile programming and maximizing self- consumption.
- **200A microgrid interconnection device** - disconnects the house loads from the grid in case of a power outage.
- Smart EV charger (optional)

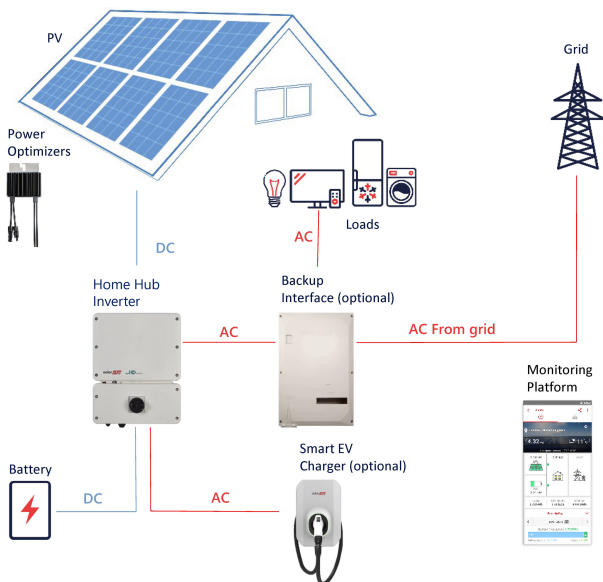

NOTE

- Additional SolarEdge inverters can be connected over RS485. The inverters will participate in export limitation, Smart Energy Management and backup operation.
- PV modules connected to Power Optimizers are not mandatory for charge/discharge profile programming.

Installation equipment list

Standard tools can be used during the installation of the SolarEdge system. The following is a recommendation of the equipment needed for installation:

1. 4 mm Allen torque screwdriver for the inverter enclosure screws
2. Standard torque flat-head screwdriver set
3. Non-contact voltage detector
4. Cordless drill (clutch) or screwdriver and bits suitable for the surface on which the inverter and optimizers will be installed and for opening the Connection Unit drill guides. Use of an impact driver is *not* allowed.
5. Mounting hardware (stainless bolts, nuts, and washers) for attaching:
 - the mounting brackets to the mounting surface

- the Power Optimizer to the racking (not required for smart modules)

6. Tools:

- Wire cutters
- Wire strippers
- Voltmeter
- Mobile phone with latest SolarEdge Go version

For installing the communications options, you may also need the following:







- For Ethernet:
 - CAT6 twisted pair Ethernet cable with RJ45 connector
- If using a CAT6 cable spool:
 - RJ45 plug and RJ45 crimper For RS485 / CAN Bus
- Four- or six-wire shielded twisted pair cable
- Watchmaker precision screwdriver set

Inverter transport and storage

Transport the inverter in its original packaging, facing up and without exposing it to unnecessary shocks. If the original package is no longer available, use a similar box that can withstand the weight of the inverter (refer to the inverter weight in the specification datasheet provided with the unit), has a handle system and can be closed fully.

Store the inverter in a dry place where ambient temperatures are -13°F to 140°F (-25°C to +60°C).

Safety

-  **WARNING!**
The metallic enclosure of the Power Optimizer must be grounded in accordance with the product's listing and local and national codes.
- AVERTISSEMENT!**
L'enceinte métallique de l'optimiseur de puissance doit être mise à la terre en accord avec les réglementations locales et nationales.
-  **WARNING!**
When modifying an existing installation, turn OFF the inverter ON/OFF/P switch and the AC circuit breaker on the main AC distribution panel.
- AVERTISSEMENT!**
Avant de faire ces étapes, éteignez l'onduleur monophasé en mettant sur OFF l'interrupteur ON/OFF/P situé au bas de l'onduleur.
-  **CAUTION!**
Power Optimizers are IP68/NEMA6P rated. Choose a mounting location where Power Optimizers will not be submerged in water.
- ATTENTION!**
Les optimiseurs de puissances sont compatibles à la norme IP68/NEMA6P. Choisissez le lieu de montage tel que l'optimiseur ne puisse pas être submergé par l'eau.
-  **CAUTION!**
The Power Optimizer must be operated according to the technical specifications provided with the Power Optimizer.
- ATTENTION!**
Cette unité doit être opérée suivant les instructions trouvées dans le manuel fourni avec le produit.
-  **CAUTION!**
Cutting the Power Optimizer input or output cable connector is prohibited and will void the warranty.
- ATTENTION!**
Sectionner les câbles d'entrées ou de sortie de l'optimiseur est interdit et annule sa garantie.
-  **CAUTION!**
All PV panels must be connected to a Power Optimizer.

ATTENTION!

Tous les modules doivent être connectés à un optimiseur de puissance.

CAUTION!

If you intend to mount the Power Optimizers directly to the panel or panel frame, first consult the panel manufacturer for guidance regarding the mounting location and the impact, if any, on panel warranty. Drilling holes in the panel frame should be done according to the panel manufacturer instructions.

ATTENTION!

Pour installation à même le module ou la monture du module, consultez d'abord le fabricant du module sur la position et son impact sur la garantie du module. Le perçage de trous dans le cadre du module devra se faire suivant les instructions du fabricant.

CAUTION!

Installing a SolarEdge system without ensuring compatibility of the panel connectors with the Power Optimizer connectors may be unsafe and could cause functionality problems such as ground faults, resulting in inverter shut down.

To ensure mechanical and electrical compatibility of the Power Optimizer connectors with the PV panel connectors to which they are connected, use identical connectors from the same manufacturer and of the same type on the Power Optimizers, panels, and the inverter DC input. Alternatively, verify that the connectors are compatible in the following way:

- The panel connector manufacturer should explicitly verify compatibility with the Power Optimizer connectors and the Inverter DC input connectors.
- A third-party test report by one of the listed external labs (TUV, VDE, Bureau Veritas UL, CSA, InterTek) should be obtained, verifying the compatibility of the connectors.

For more information, refer to

<https://www.solaredge.com/sites/default/files/optimizer-input-connector-compatibility.pdf>



ATTENTION!

Les connecteurs du module doivent être mécaniquement compatibles avec les optimiseurs de puissance. Sinon, le système SolarEdge installé peut être dangereux ou causer des problèmes fonctionnels, tels que les défauts de terre, qui peuvent provoquer un arrêt de l'onduleur. Afin d'assurer la compatibilité mécanique entre les optimiseurs de puissance SolarEdge et les modules auxquels ils sont connectés:

- Utiliser des connecteurs identiques du même fabricant et du même type aussi bien pour les optimiseurs de puissance que pour les modules.



- Vérifiez que les connecteurs sont compatibles de la manière suivante:
 - Le fabricant du connecteur doit explicitement vérifier la compatibilité avec le connecteur SolarEdge.
 - Un rapport de test de tierce partie doit être effectué par l'un des laboratoires externes indiqués ci-dessous:(TUV, VDE, Bureau Veritas UL, CSA,Intertek), qui vérifiera la compatibilité des connecteurs.

Pour plus d'informations, consultez

<https://www.solaredge.com/sites/default/files/optimizer-input-connector-compatibility.pdf>

**IMPORTANT SAFETY FEATURE**

Modules with SolarEdge Power Optimizers are safe. They carry only a low safety voltage before the inverter is turned ON. As long as the power optimizers are not connected to the inverter or the inverter is turned OFF, each Power Optimizer will output a safe Voltage of 1V.

SolarEdge Power Control System

New SolarEdge inverters are now integrated with Power Control System (PCS) technology, enabling installation of PV systems having 50% more capacity without requiring costly and time-consuming main electrical panel upgrades.

With the new embedded PCS technology, SolarEdge inverters can monitor, balance, and control the currents on the main panel busbar, resulting in the ability to install larger PV systems than allowed today by the National Electrical Code 120% rule¹. This means that a typical home with a 200A main panel would be able to install up to three SolarEdge 11.4kW inverters without going through a main panel upgrade².

¹National Electric Code (NEC) 2020 705.12

²As per the local utility permit.

Supporting inverters

PCS is supported by Home Hub inverters having part numbers ending in "75", "78" and "Z8", for example:

- USEXXXH-USMNBE78
- SEXXXXH-USMNUBL75
- USEXXXH-USSKBEZ8

PCS certification training

Before enabling the PCS feature, it is mandatory to complete the SolarEdge PCS Certification in the EDGE Academy. To access the training, scan the QR code.



Activate busbar current management

For busbar current management compatibility and activation details refer to <https://knowledge-center.solaredge.com/sites/kc/files/se-activate-busbar-current-management-application-note-nam.pdf>

Installation guidelines

For the minimum and maximum number of Power Optimizers in a PV string (PV string length), see the Power Optimizer datasheets. Refer to the Designer for PV string length verification. The Designer is available on the SolarEdge website at: <https://www.solaredge.com/us/products/installer-tools/designer#/>.

The total cable length of home run cables from the first and the last Power Optimizers to the single-phase inverter may not exceed 1000ft (300m).

SolarEdge allows the use of extension cables between the following units:

- Power Optimizer and a PV module
- Two PV modules connected in series to a Power Optimizer
- Two Power Optimizers
- Power Optimizer and an inverter

Using an extension cable between a Power Optimizer and a PV module

For S-Series Commercial Power Optimizers with part numbers in the format S1xx-1xxxxxx:

Total round-trip cable length between the Power Optimizer (+) and (-) input terminals of up to 52ft (16m) may be installed per Power Optimizer. 26ft (8m) for DC+, and 26ft (8m) for DC-.

For P-Series Power Optimizers with the 4-type suffix in their part number (Pxxx-4xxxxxx) and for the Mxxxx-Series:

Total round-trip cable length between the Power Optimizer (+) and (-) input terminals of up to 52ft (16m) can be installed per Power Optimizer. 26ft (8m) for DC+, and 26ft (8m) for DC-.

For S-Series Residential Power Optimizers, and P-Series Residential Power Optimizers with the 5-type suffix in their part number (Pxxx-5xxxxxx):

Total round-trip cable length between the Power Optimizer (+) and (-) input terminals of up to 6ft (1.8m) can be installed per Power Optimizer. 3ft (0.9m) for DC+, and 3ft (0.9m) for DC-.

Using Extension Cables Between two Power Optimizers or between a Power Optimizer and the Inverter

Extension cables may be installed between two Power Optimizers in the following cases:

- From a Power Optimizer in one row to another Power Optimizer in the next row.
- Around obstacles or pathways within the same row.
- From the end of the PV string to the inverter.

For connecting homerun DC cables from Power Optimizers to the inverter, use cables with the following cross-sections:

- For MC4 connectors: 8-14 AWG (2.5-10mm²)
- For DC terminal blocks inside the inverter or Connection Unit (if applicable): 6-14 AWG/ 2.5-16 mm²

Installing Power Optimizers

Frame-mounted Power Optimizers are mounted directly on the panel frame, regardless of racking system (rail-less or with rails). For installation of frame-mounted Power Optimizers, refer to http://www.solaredge.com/sites/default/files/installing_frame_mounted_power_optimizers.pdf.

- The Power Optimizer may be placed in any orientation.
- Position the Power Optimizer close enough to its panel so that their cables can be connected.

- Make sure to use Power Optimizers that have the required output and input conductor length.
- Completely shaded panels may cause their Power Optimizers to temporarily shut down. This will not affect the performance of the other Power Optimizers in the PV string, as long as the minimum number of unshaded Power Optimizers connected in a PV string of panels is met. If under typical conditions fewer than the minimum Power Optimizers are connected to unshaded panels, add more Power Optimizers to the PV string.

To allow for heat dissipation, maintain the following clearance:

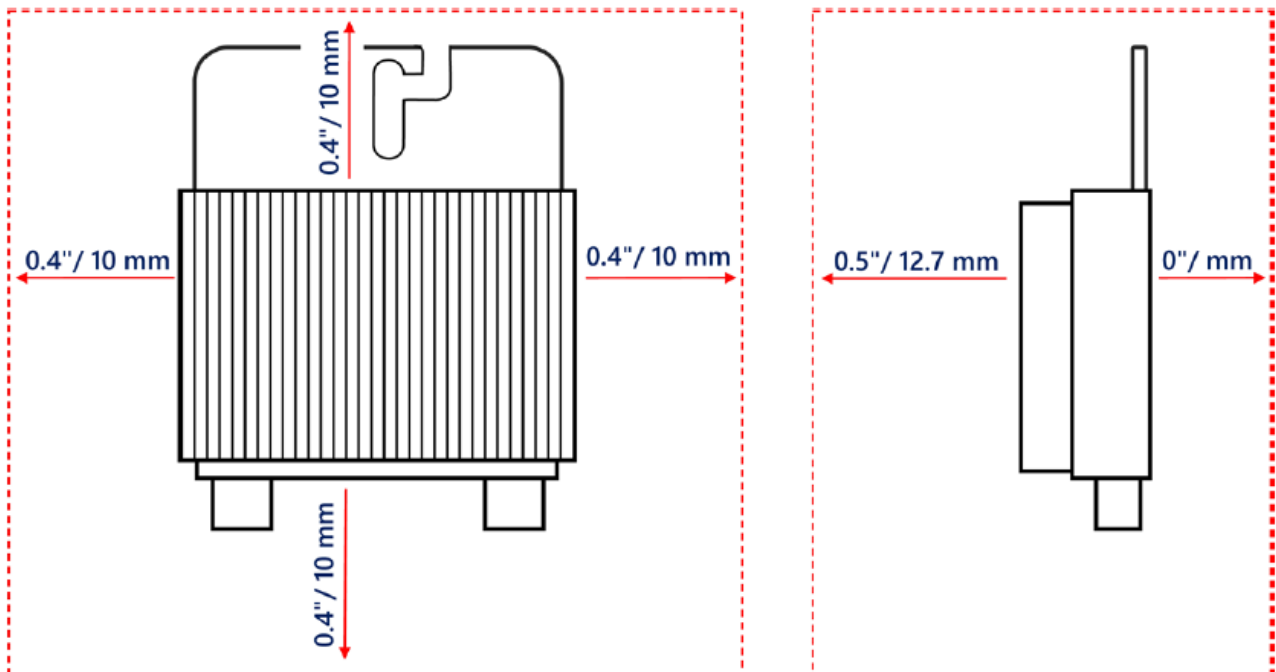

- Equipment grounding tightening torques: 4-6 AWG: 45 lb-in, 8 AWG: 40 lb-in, 10-14

AWG: 35 lb-in.

When installing PV panels in a confined space, such as Building-integrated photovoltaic (BIPV) panels, ventilation measures may be required to ensure that the Power Optimizers are not exceeding the maximum temperatures stated in their specifications.

Mounting the Power Optimizers

For each Power Optimizer:

1. Determine its mounting location and use the Power Optimizer mounting bracket to attach it to the support structure, as shown in the figure. SolarEdge recommends mounting the Power Optimizer in a location protected from direct sunlight.

For frame-mounted Power Optimizers, follow the instructions supplied with the Power Optimizers, or refer to https://www.solaredge.com/sites/default/files/installing_frame_mounted_power_optimizers.pdf



2. Attach each Power Optimizer to the rack using M6 (1/4") or M8 stainless steel bolts, nuts and washers, or other mounting hardware. Apply a torque of 6.5 to 7ft·lbf (9 to 10 N·m).

For 3NA series Power Optimizers, SolarEdge recommends mounting the Power Optimizer on a rail with the smooth side facing out, so that the Power Optimizer body will prevent its rotation.

Grounding the Power Optimizers



IMPORTANT

IMPORTANT NOTE! If the racking manufacturer has supplied grounding solutions with their hardware, make sure that you follow their instructions.

The metallic enclosure of the Power Optimizer must be grounded in accordance with the requirements of local and national codes.

AVERTISSEMENT!

L'enceinte métallique de l'optimiseur de puissance doit être mise à la terre en accord avec les réglementations locales et nationales.

Mounting the Power Optimizers on a grounded metal rail

1. Insert the supplied 5/16" stainless steel grounding star washer between the railing and the flat side of the mounting bracket.
2. Tighten the bolt to a torque of 7ft·lbf (9.5N·m).

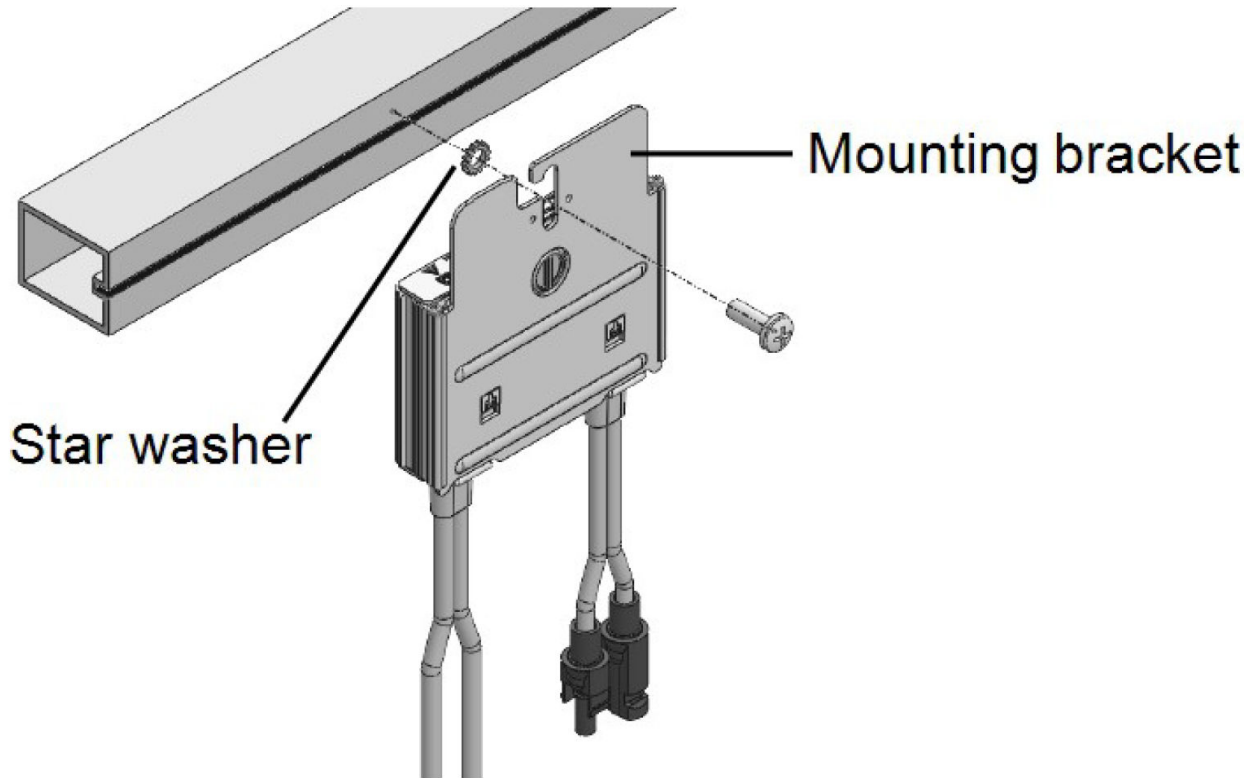

Make sure that the grounding washer breaks through the anodized coating of the railing to ensure good conductivity.

Mounting Power Optimizers on rails with sliding nut fasteners:

If the star washer cannot be used, use a SolarEdge grounding plate (purchased separately) between the railing and the flat side of the mounting bracket. Use specific mounting hardware as required. Apply a torque of 7ft·lbf (9.5N·m)

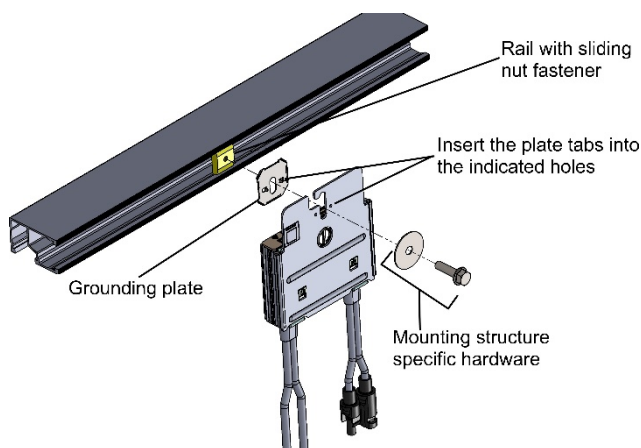

Mounting Power Optimizers on ungrounded structures

In the case of ungrounded structures like a wooden structure, and neither the star washer nor the grounding plate is suitable, use the SolarEdge grounding lug (purchased separately) with a grounding conductor installed according to the supplied instructions. The grounding terminal accepts wire sizes of 6 to 14 AWG and must be sized for equipment grounding as

per NEC 250.122 requirements. Tighten the screw connecting the Power Optimizer to the frame and the grounding terminal. Apply a torque of 7ft·lbf (9.5N·m).

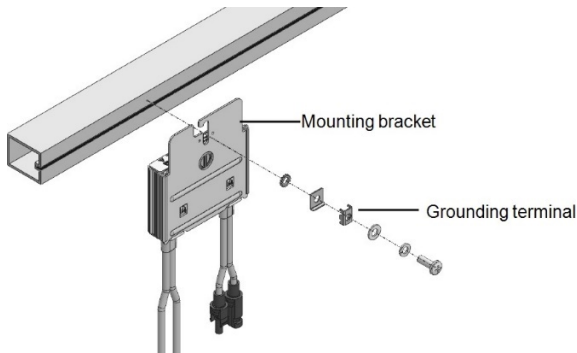

Completing the Power Optimizer installation

1. Verify that each Power Optimizer is securely attached to the panel support structure.
2. Record the serial numbers and locations of each Power Optimizer as described in [Reporting and Monitoring Installation Data](#).

Connecting a PV panel to a Power Optimizer



NOTE

Improper wiring may cause electrical faults in a PV system. To avoid electrical faults, verify proper locking of connectors and avoid cable tension and friction. Proper planning, materials and installation reduce the risk of electric arcing, short-circuits and ground faults in the PV system.

Images are for illustration purposes only. Refer to the label on the product to identify the plus (+) and minus (-) input and output connectors.

For each Power Optimizer:

1. Connect the Plus (+) output connector of the panel to the Plus (+) input connector of the Power Optimizer.
2. Connect the Minus (-) output connector of the panel to the Minus (-) input connector of the Power Optimizer.

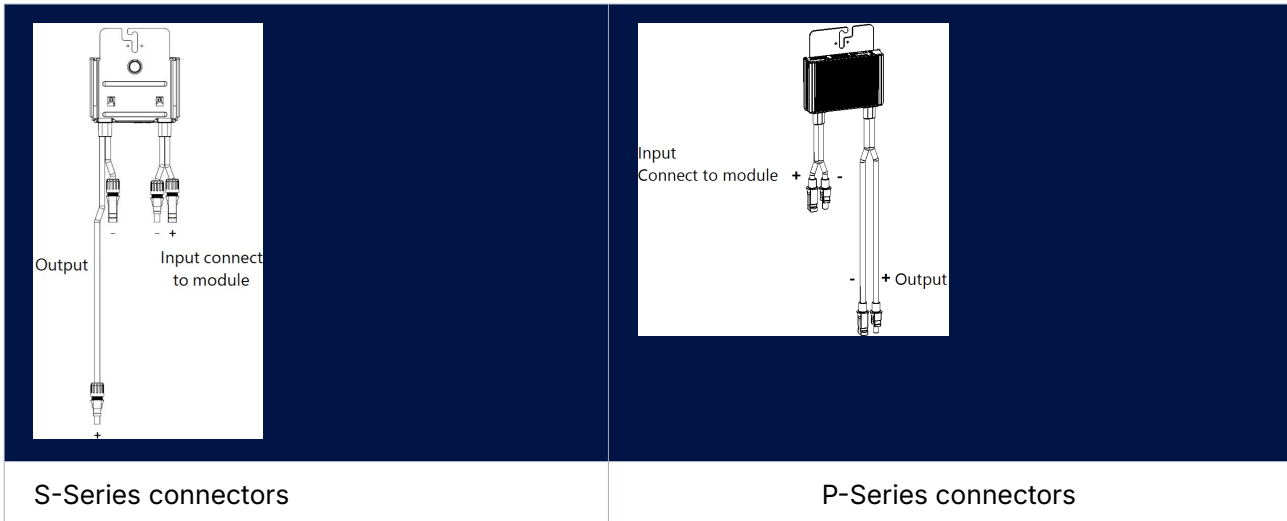

Connecting Power Optimizers in strings

The number of Power Optimizers in a string does not have to be the same in each string. The minimum and maximum string lengths are specified in the Power Optimizer datasheets. Refer to [Designer](#) for string length verification.



1. Connect the Minus (-) output connector of the string's first Power Optimizer to the Plus (+) output connector of the string's second Power Optimizer. When connecting S-Series Power Optimizers, be sure to connect the short Minus (-) output connector of one Power Optimizer to the long Plus (+) output connector of the next Power Optimizer.
2. To minimize electromagnetic interference (EMI), make sure to minimize the distance between the positive and negative DC cables.

For detailed instructions see [EMI performance](#).



3. Connect the rest of the Power Optimizers in the string in the same manner.

**WARNING**

When using a dual-input Power Optimizer and some inputs are not used, seal the unused input connectors with the supplied pair of seals.

AVERTISSEMENT!

Si un optimiseur à double entrées est utilisé et que certaines entrées ne sont pas connectées, fermez ces entrées avec la paire de couvercles fournie

4. If you intend to monitor the installation using the monitoring platform, record the physical location of each Power Optimizer, as described [here](#). [48]

Verifying correct Power Optimizer connection

When a PV Panel is connected to a Power Optimizer, the Power Optimizer output voltage is a safe voltage of 1V ($\pm 0.1V$). The total PV string voltage should equal 1V multiplied by the number of Power Optimizers connected in series in the PV string. For example, if 10 Power Optimizers are connected in a PV string, then the output voltage should be 10V. Make sure that the PV panels are exposed to sunlight during this process. The Power Optimizer only turns ON if the PV panel generates power of at least 2W.

In SolarEdge systems, due to the introduction of Power Optimizers between the PV panels and the inverter, the short circuit current I_{SC} and the open circuit voltage V_{OC} hold different meanings from those in traditional systems.

For more information about the SolarEdge system's PV string Voltage and current, refer to V_{OC} and I_{SC} in this [Technical note](#).



To verify the correct Power Optimizer connection:

Measure the voltage of each PV string individually before connecting it to the other PV strings or to the inverter. Verify the correct polarity using a voltmeter. Use a voltmeter with a measurement resolution of at least 0.1V.

**NOTE**

Since the inverter is not yet operating, you can measure the PV string voltage and verify the correct polarity on the DC wires inside the Connection Unit.

For troubleshooting Power Optimizer operation problems, refer to [Power Optimizer troubleshooting](#) [60]

Proper Power Optimizer connection can be verified in the [Designer](#) application.



Installing the inverter

Install the inverter either before or after the PV Panels and the Power Optimizers have been installed.

Inverter package contents

- One Home Hub inverter
- One mounting bracket
- Two M5×14mm Allen screws with a spring washer and flat washer for fastening the inverter to the mounting bracket

Identifying the inverter

Refer to the sticker on the inverter that specifies its **Serial Number** and its **Electrical Ratings**. Provide the serial number when contacting SolarEdge support. The serial number is also required when opening a new site in the SolarEdge monitoring platform.

Inverter interfaces

The following figure shows the inverter components and its connectors located at the bottom of the inverter.

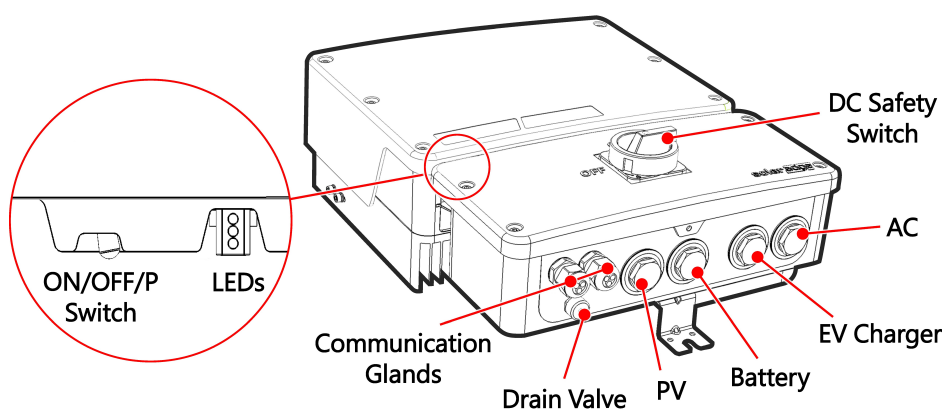

- **AC conduit entry** - for AC connection to the grid or Backup Interface
- **PV conduit entry** - for DC connection to SolarEdge Power Optimizers

- **EV conduit entry** - for AC connection to the Standalone EV Charger
- **Battery conduit entry** - for DC connection to the battery
- **DC Safety switch** - connects and disconnects the DC power to the system
- **Two communication glands:** for connection of inverter communication options. Each gland has three openings.
- **ON/OFF/P switch:**
 - **ON (1)** - After Power Optimizer pairing is complete, turning this switch ON starts the operation of the Power Optimizers, enables power production, and allows the inverter to begin exporting power to the utility grid.
 - **OFF (0)** - Turning this switch OFF reduces the Power Optimizer voltage to a low safety voltage and inhibits exportation of power. When this switch is OFF, the control circuitry remains powered up.
 - **P** – Holding the switch in this position and then releasing it enables you to view system information via the LEDs, and to perform the following functions:

P Position Duration	Function	Comments
Switch held at P for 2 seconds , then released.	<ul style="list-style-type: none"> • Displays (via LEDs) production information for 5 seconds, or error type indications (if exist) for 5 seconds. • Activates the Wi-Fi access point for connecting to SolarEdge Go. 	<p>While the switch is in the P position, all LEDs are ON.</p> <p>When the switch is released, all LEDs turn OFF for 0.5 sec and then display the production or error indication.</p>
Switch held at P for more than 30 seconds , then released	Resets the communication board	Reset is indicated by all 3 LEDs blinking fast simultaneously
Switch held at P for more than 5 seconds , then released.	Starts pairing	Pairing is indicated by all 3 LEDs blinking simultaneously.

- **LEDs:** three LEDs provide system information such as errors or performance indications. This is done based on their color and state. The LED states are defined as follows:

LED State	Description
Blinking	Turns ON and OFF for the same duration
Flickering	Turns ON for 100 mS and turns OFF for 5 seconds

LED State	Description
Alternating	Alternate LED flashes

For more information, refer to <https://www.solaredge.com/leds>.



The main LED indications are:

- Blue ON - the inverter is communicating with the monitoring platform
- Green ON - the system is producing
- Green blinking - AC is connected but the system is not producing
- Red ON - system error

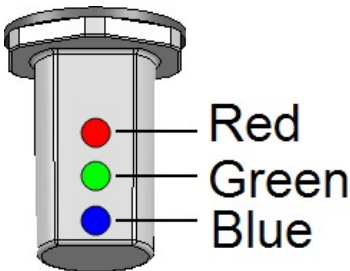

The following table describes system performance information by LED color and ON/OFF/P switch position.

Indication	ON/ OFF/ P Switch Position	LED Color			Comment
		Red	Green	Blue	
Power Optimizers not paired	ON (1)	OFF	Blinking	S_OK: ON No S_OK: OFF	S_OK: ON communication with the monitoring platform is established.
Pairing		Blinking	Blinking	Blinking	

Indication	ON/ OFF/ P Switch Position	LED Color			Comment
Wake-up/ Grid Monitoring		OFF	Blinking	Blinking	
System Producing		OFF	ON	S_OK: ON No S_OK: OFF	
Night mode (no production)		OFF	Flickering	S_OK: ON No S_OK: OFF	

Indication	ON/ OFF/ P Switch Position	LED Color			Comment
		Red	Green	Blue	
Inverter is OFF (Safe DC)	OFF (0)	OFF	Blinking	S_OK: ON No S_OK: OFF	
Inverter is OFF (DC not safe)		Blinking	Blinking	S_OK: ON No S_OK: OFF	
Inverter configurati on or reboot	ON / P	ON	ON	ON	
Inverter firmware upgrade	ON / P	Alternating	Alternating	Alternating	The upgrade process can take up to 5 minutes
Error	Any	ON	ON/ OFF/ Blinking/ Flickering	ON/ OFF / Blinking	Refer to Appendix A [57]

The following table describes production percentage of AC information by LED color and ON/OFF/P switch position.

Indication	ON/ OFF/ P	LED Color			Comment
	Switch Position	Red	Green	Blue	
Percentage of AC Production: 0 %	ON (1)	OFF	OFF	OFF	This indicates power production as a percentage of rated peak AC output power
Percentage of AC Production: 0 - 33 %		OFF	ON	OFF	
Percentage of AC Production: 33 - 66 %		OFF	OFF	ON	
Percentage of AC Production: 66 - 100 %		OFF	ON	ON	

Mounting the inverter

The inverter is supplied with a mounting bracket kit:

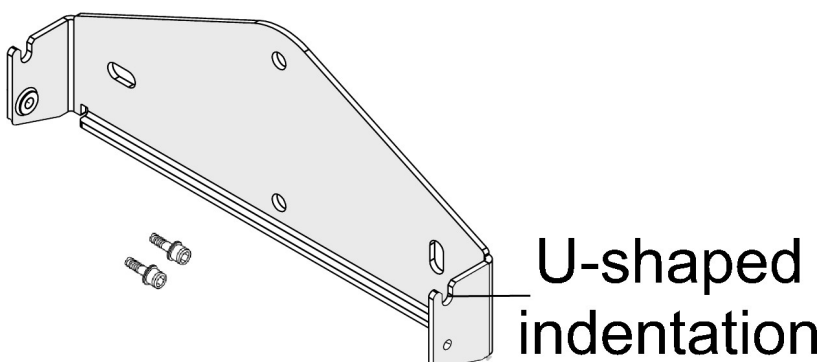

NOTE

Make sure the mounting surface or structure can support the weight of the inverter.



CAUTION

SolarEdge inverters and Power Optimizers can be installed at a minimum distance of 50 m / 164 ft from the shoreline of an ocean or other saline environment, as long as there are no direct saltwater splashes on the inverter or Power Optimizer.

For SolarEdge inverters installed at a distance of 200 m / 655 ft or closer to the shoreline, special brackets purchased separately from SolarEdge and SS304 stainless screws are required. For details, please contact your local sales representative.

ATTENTION!

Les onduleurs SolarEdge peuvent être installés à une distance minimum de 50m de la ligne d'eau de l'océan ou autre environnement salin, tant qu'il n'y a pas d'éclaboussements d'eau salée directs sur l'onduleur.

Pour les onduleurs SolarEdge installés à une distance de 200 m ou moins du rivage, des supports spéciaux achetés séparément auprès de SolarEdge et des vis inox SS304 sont nécessaires. Pour les détails, veuillez contacter le commercial de votre région.

1. Identify the inverter mounting location on a wall, stud frame, or on a pole. SolarEdge recommends mounting the inverter in a location protected from direct sunlight.
2. To enable proper heat dissipation, maintain the following minimum clearance areas between the inverter and other objects:

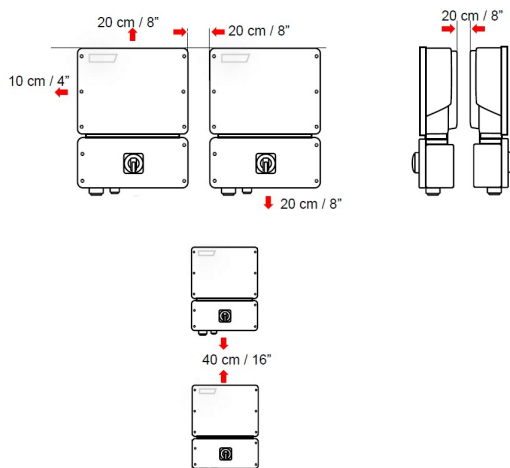

When installing a single inverter, leave sufficient space around it as follows:

- 8" (20cm) from the top of the inverter.
- At least 4" (10cm) from the bottom of the inverter

If conduit entry to the Connection Unit is from the bottom, leave sufficient clearance for the conduits as well.

- 4" (10cm) from the right and left sides of the inverter.

When installing multiple inverters, leave sufficient space around them as follows:

- When installing inverters side by side, leave at least 8" (20cm) between inverters.
- When installing inverters one above the other, leave at least 16" (40cm) between inverters.

Installing the mounting bracket

1. Position the mounting bracket against the wall/pole and mark the drilling hole locations. Refer to the *Mechanical Specifications* appendix below for inverter and mounting bracket dimensions.
2. Drill the holes and mount the bracket. Verify that the bracket is firmly attached to the mounting surface.

Hanging the inverter on the bracket:

1. To lift the unit into place, grasp the sides or the top and bottom of the inverter. Do not lift the inverter while holding the Safety Switch as it might get damaged.
2. Lower the inverter onto the U-shaped indentations. Lie the inverter flat against the wall or pole.
3. Insert the two supplied screws through the outer heat sink fin on both sides of the inverter and into the bracket.
4. Tighten the screws to a torque of 2.9ft·lbf (4.0N·m).

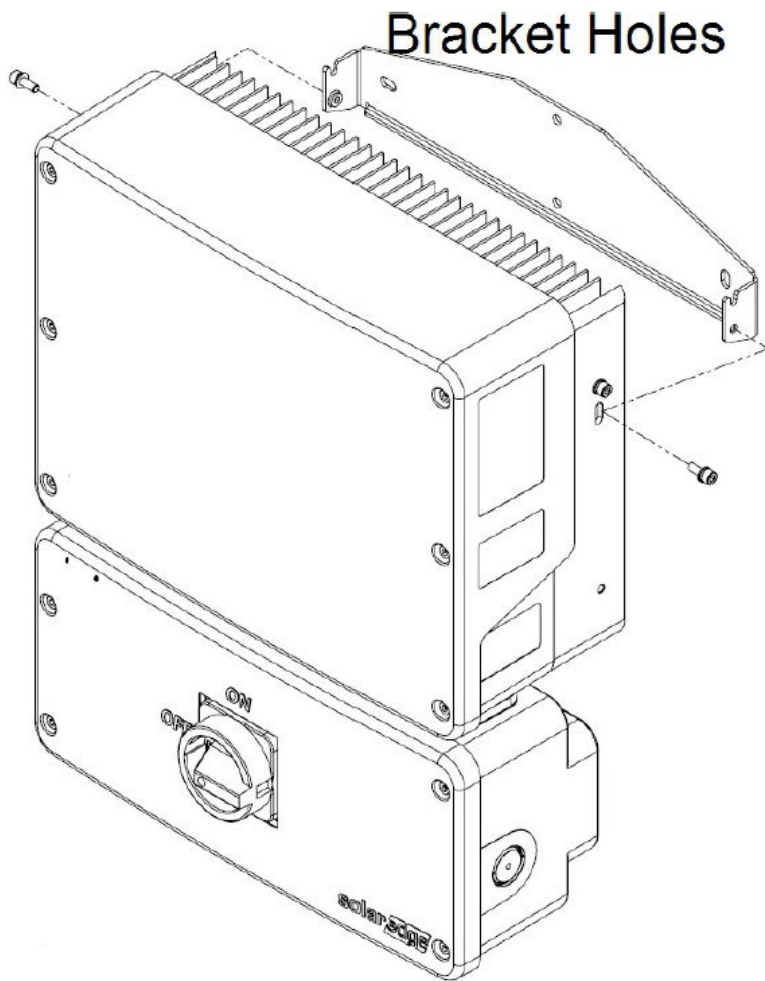

Attaching the connection unit bracket (optional)

To secure the connection unit bracket to the wall/pole:



NOTE

In case of inverter replacement with the Connection Unit still mounted, it is recommended to use all 3 holes.

1. Mark the location of the bracket holes for the Connection Unit.
2. Remove the inverter from the wall/pole.

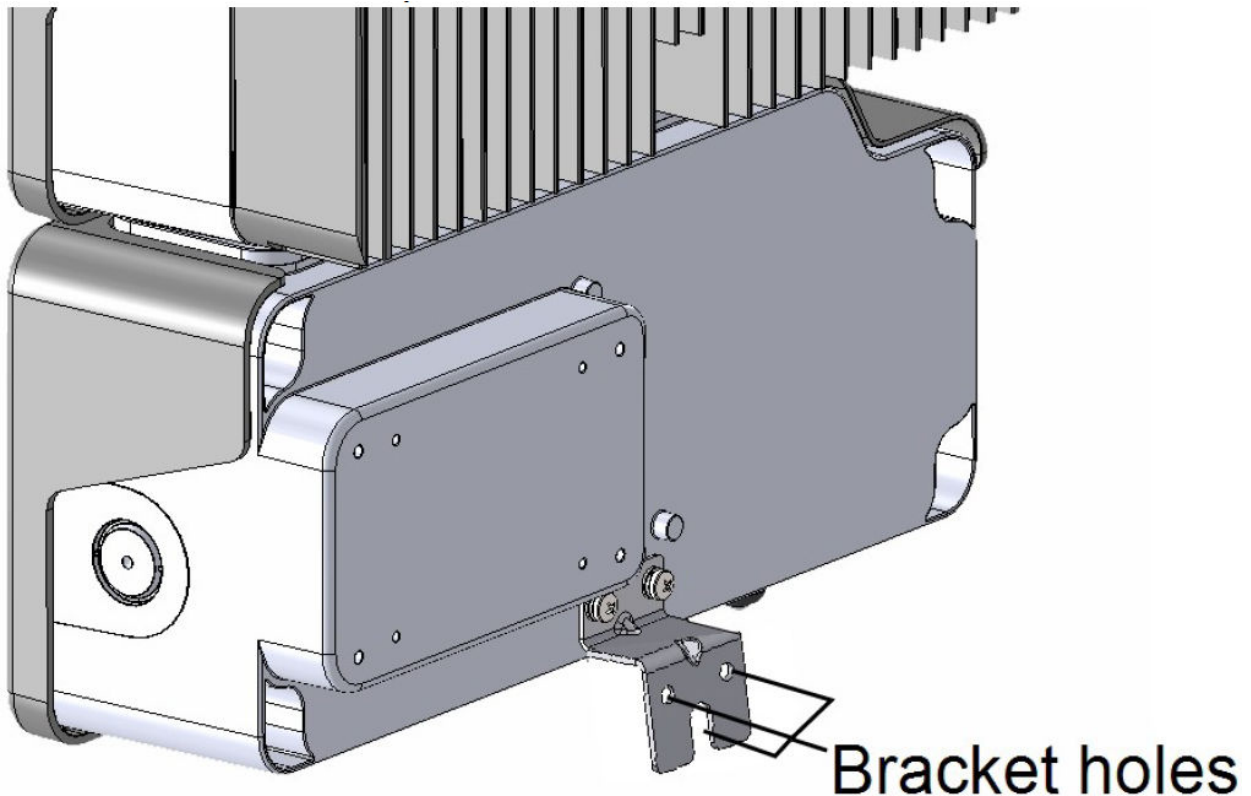

3. Drill the holes for the Connection Unit bracket.
4. Hang the inverter on its mounting bracket.
5. Fasten the Connection Unit bracket using standard screws.
6. Insert the screws at the top of the inverter brackets and fasten.
7. Verify that the inverter is firmly attached to the mounting surface.

Selecting a Residual Current Device (RCD)



IMPORTANT

IMPORTANT SAFETY FEATURE

All SolarEdge inverters incorporate a certified internal Residual Current Device (RCD) to protect against possible electrocution and fire hazard in case of a malfunction in the PV array, cables or the inverter. There are two trip thresholds for the RCD as required for certification. The default value for electrocution protection is 30mA, and for slow rising current, the default is 300mA.

If an external RCD is required by local regulations, check which type of RCD is required for the relevant electric code. Install the residual-current device (RCD) in accordance with the applicable local standards and directives. SolarEdge recommends using a type- A RCD. The recommended RCD value is 100 mA or 300 mA unless a lower value is required by the specific local electric codes. When required by local regulations, the use of an RCD type B is permitted.

**NOTE**

For multiple inverters, an RCD per inverter is required.

In installations where the local electric code requires an RCD with a lower leakage setting, the discharge current might result in nuisance tripping of the external RCD. The following steps are recommended to avoid nuisance tripping of the external RCD:

- Select the appropriate RCD for correct operation of the installation: An RCD with a rating of 30 mA may actually trip at a leakage as low as 15 mA (according to IEC 61008). High quality RCDs will typically trip at a value closer to their rating.
- Configure the trip voltage of the inverter's internal RCD to a lower value than the trip current of the external RCD. The internal RCD will trip if the current is higher than the allowed current, but because the internal inverter RCD automatically resets when the residual currents are low, it prevents manual resetting.

For detailed information, refer to the [RCD Selection for SolarEdge Inverters Application Note](#)



Installing the battery (optional)

Install the battery in accordance with the manufacturer's instructions.

For the SolarEdge Home Battery Quick installation guide, refer to <https://knowledge-center.solaredge.com/sites/kc/files/se-home-battery-400v-quick-installation-guide-nam.pdf>



In addition, follow these guidelines:

- Make sure the battery's circuit breaker switch is OFF
- Measure the necessary length between the and the battery for all cables
- Mark the polarity on the DC cables

Connecting the inverter

This chapter explains how to connect the inverter to:

- The AC grid
- DC strings of modules with Power Optimizers
- Smart EV Charger
- Battery

Installing conduits

Before connecting the inverter, install all the conduits.

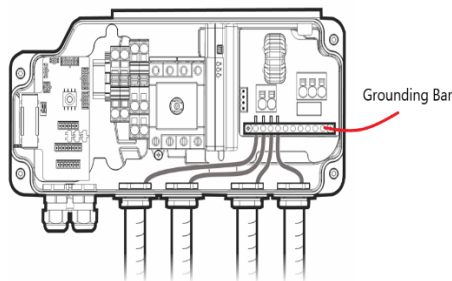

To install a conduit:

1. Turn the DC Safety Switch OFF.
2. Release the four Allen screws of the Connection Unit cover and remove the cover.



CAUTION

When removing the cover, make sure not to damage internal components. SolarEdge will not be held responsible for any components damaged as a result of incautious cover removal.

3. Install a conduit of the required diameter:
 - To install a 1" conduit, remove the conduit plug together with the reducing washer.
 - To install a 3/4" conduit, use the supplied reducing washer.
 - To install a smaller conduit, use a reducing washer of the appropriate size (not supplied).

If required, ground the conduit by connecting it to the grounding bar.

Connecting the inverter to the AC grid

For connections of the inverter to the AC grid, use a 14–4 AWG cable.

For more wiring information, refer to the [SolarEdge Recommended AC Wiring Application Note](#)



To connect to the AC Grid:

1. Turn off the AC circuit breaker on the distribution panel.
2. Strip 2.5" (60mm) of the external cable insulation and strip 0.7" (18mm) of the internal wire insulation.

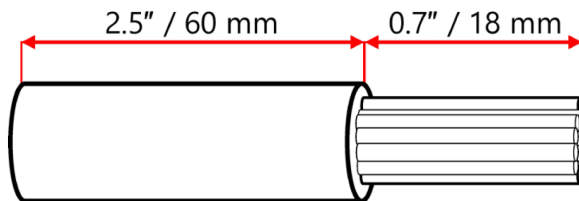

3. Pass the AC cable through the conduit.
4. Connect the wires to the AC terminals as shown below.

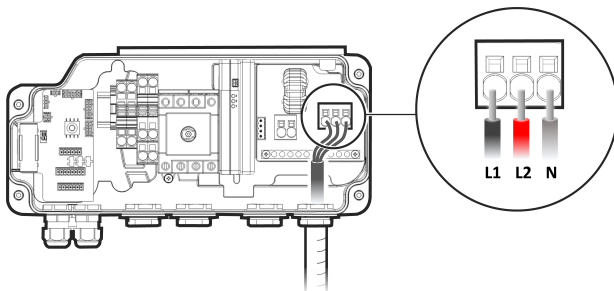

Connecting the DC strings to the inverter

Connect the string to the DC input terminal pairs. If required, connect additional strings in parallel using an external combiner box or branch cables before connecting to the inverter.



NOTE

Functional electrical earthing of DC-side negative or positive poles is prohibited because the inverter has no transformer. Grounding (earth ground) of panel frames and mounting equipment of the PV string panels is acceptable.

SolarEdge fixed input voltage architecture enables the parallel strings to be of different lengths. Therefore, they do not need to have the same number of Power Optimizers, as long as the length of each string is within the permitted range.

To connect the DC strings:

1. Strip 5.16"/8 mm of the DC wires insulation.
2. Pass the DC wires through the PV conduit.

3. Connect the wires to the DC terminals as shown below. Observe the correct polarity as labeled on the terminals.

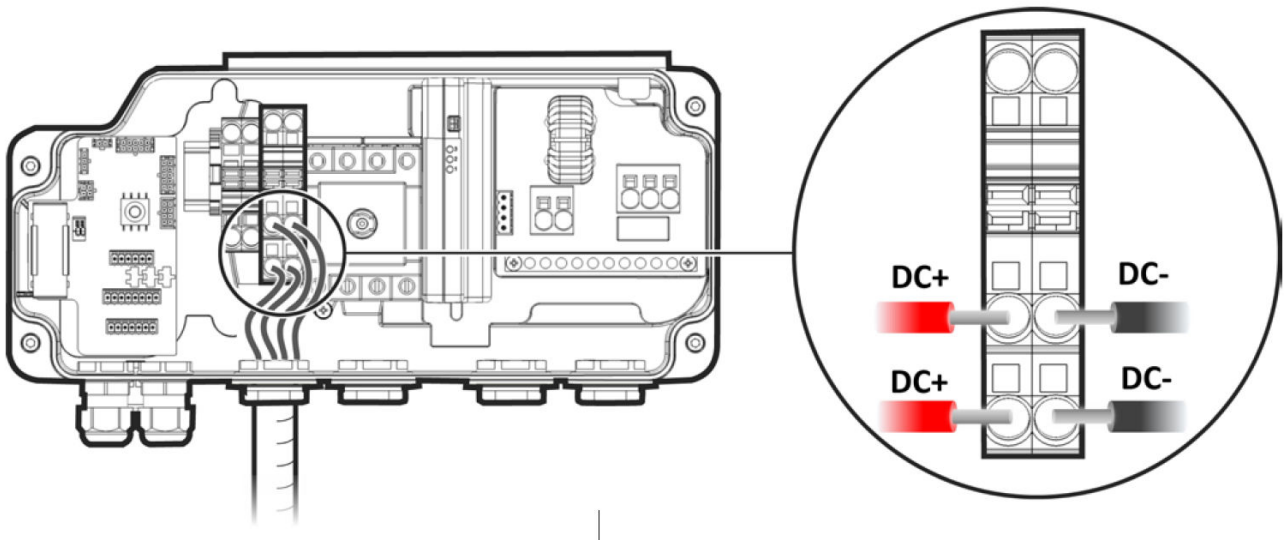

Connecting the battery (optional)

To set up communication between the SolarEdge Home Battery and the inverter, SolarEdge recommends using SolarEdge Energy Net. If SolarEdge Energy Net cannot be used, you can set up communication using an RS485 port, as explained in this section.



WARNING

- Before connecting the battery to the inverter, verify that the battery is powered off.
- Do not turn on the battery while the inverter is under production.

SolarEdge Home Battery

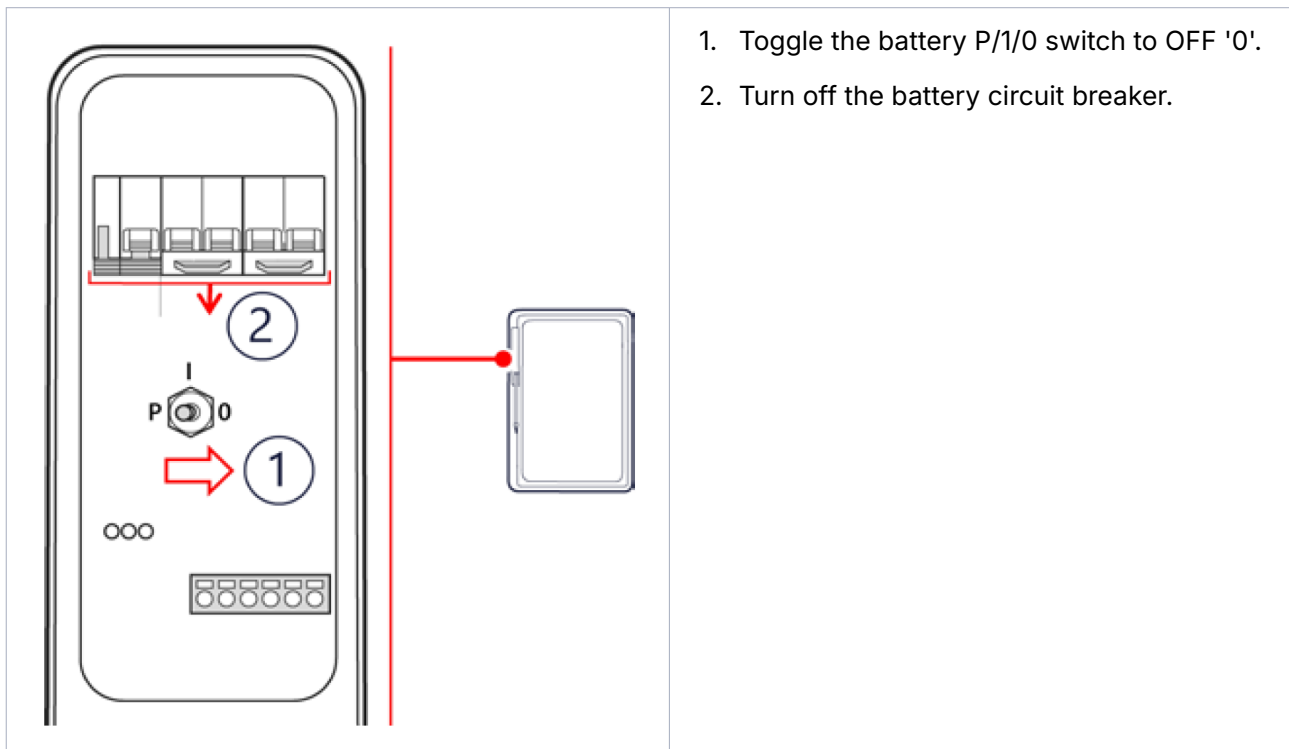

Use the following cable types:

- **DC:** a pair of DC cables, 10-12 AWG, 600V insulated.
- **Communication:** 600V CAT6 or higher communication cable with individually shielded twisted pairs and an overall foil or braided shield, with conductor size between 0.2–1 mm² (approximately AWG 24–16).

To connect communication:

1. Connect the communication cable to the battery's RS485 connector as shown below.
2. Open Communication Gland 2 at the bottom of the inverter's Connection Unit.
3. Feed the other end of the communication cable through one of the gland openings.
4. Remove the connector from the port labeled **2nd Inv-Battery** on the communication board.
5. Use the wires from the same twisted pair for the A and B wires between the battery and the inverter.

Connecting the Backup Interface

You must install the Backup Interface to enable the operation of the batteries and the backup support.

When connecting the Backup Interface to the inverter, use the following cable types:

- **AC:** 14–6 AWG cable
- **Communication:** 600V CAT6 or higher communication cable with individually shielded twisted pairs and an overall foil or braided shield, with conductor size between 0.2–1 mm² (approximately AWG 24–16).
- **12V power:**



NOTE

If the distance between the inverter and the Backup Interface is less than 49ft (15m), use the CAT6 communication cable.

If the distance is greater than 49ft (15m), use a dedicated cable of minimum 14AWG.

To connect the Backup Interface

1. Connect the AC, communication and 12V power cables to the Backup Interface, as explained in the installation manual supplied with the Backup interface.
2. Connect the other end of the AC cable to the inverter, as explained in [Connecting the Inverter to the AC grid \[34\]](#)
3. Open Communication Gland 1 at the bottom of the Connection Unit.
4. Feed the other end of the communication cable through one of the gland openings.
5. Remove the 7-pin connector from the port labeled **Backup Interface** on the communication board.
6. Connect the communication cable wires to the 7-pin connector, as shown below. For the RSD connection, see [Connecting an external RSD switch \[41\]](#).

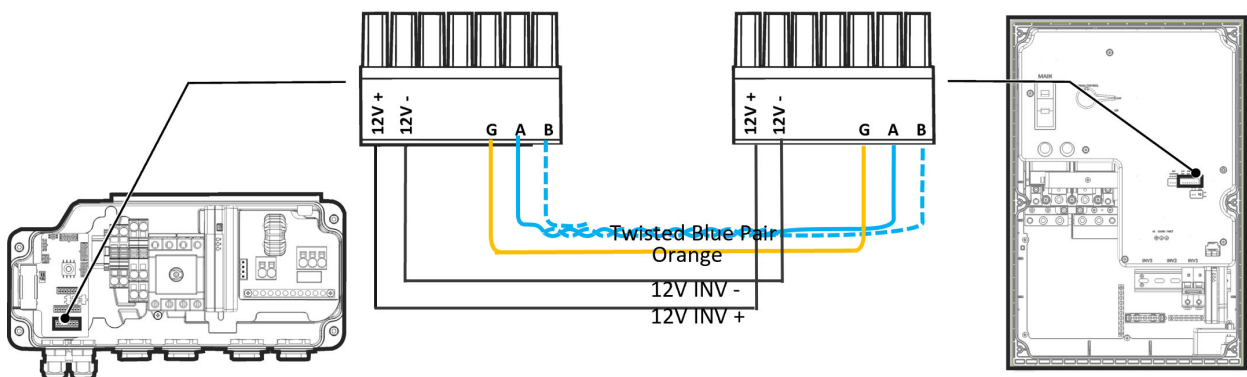

7. Close Communication Gland 1 to a torque of 50in·lbf.

Connecting the Smart EV Charger (Optional)

For the Smart EV Charger installation instructions, refer to the [Quick Installation Guide](#).



When connecting the Smart EV Charger to the inverter, use the following cable types:

- **AC:** 14-4 AWG cable
- **Communication:** 600V CAT6 or higher communication cable with individually shielded twisted pairs and an overall foil or braided shield, with conductor size between 0.2–1 mm² (approximately AWG 24–16).

To connect the Smart EV Charger:

1. Connect the AC cable and communication cable to the Smart EV Charger, as explained in the installation manual supplied with Smart EV Charger.
2. Pass the other end of the AC cable through the EV Charger conduit.
3. Connect the wires to the AC terminals, as shown below.

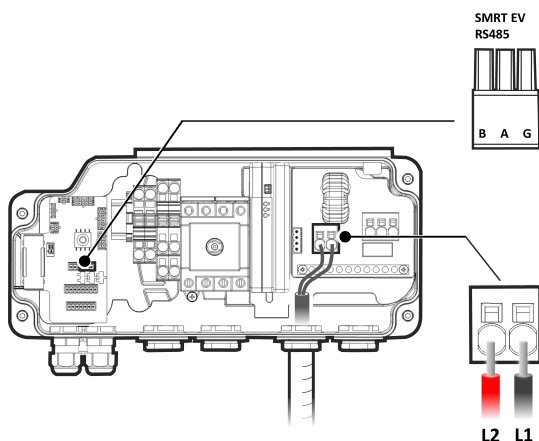

4. Open Communication Gland 2 at the bottom of the Connection Unit.
5. Feed the other end of the communication cable through one of the gland openings.
6. Connect the communication cable to the 3-pin connector labeled **SMRT EV RS485**.
7. Make sure the three DIP switches above the connector are in the down position (up—for RS485-2 the SolarEdge protocol; down—for RS485-1 the Modbus protocol).
8. Close Communication Gland 2 to a torque of 50in·lbf.

Connecting an external RSD switch

In accordance with regulation requirements, an external rapid shutdown switch must be installed to shut down the system in case of emergency.

The switch is not supplied by SolarEdge and must be purchased separately.

If the SolarEdge Backup Interface is installed as part of the system, connect the external RSD switch to the Backup Interface as shown in the Backup Interface installation guide, and connect the RSD wires from the Backup Interface to the inverter.

To connect an external RSD switch to an inverter

1. Remove the factory-installed RSD wire connecting the 7-pin Backup Interface connector to the Safety Switch. Do not disconnect the RSD+ wire.

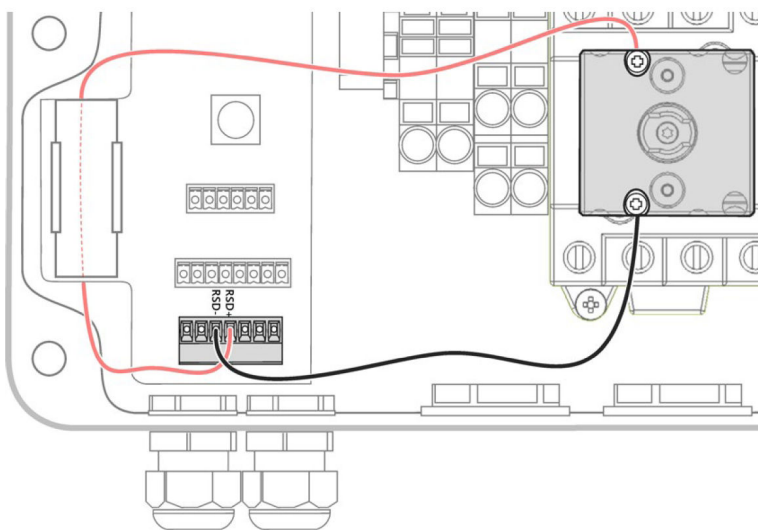

2. Pass the wires from the external RSD switch through Communication Gland 2.
3. Connect the positive wire to the Safety Switch and the negative wire to the RSD- port on the Backup Interface connector.

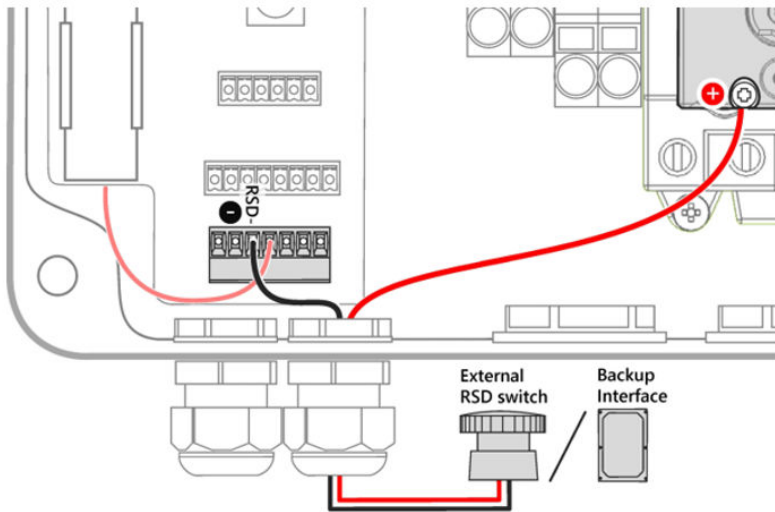

To connect an external RSD switch to multiple inverters:

1. Connect the external RSD switch to the Leader inverter, as explained above.
2. Connect wires to the RSD+ and RSD- ports of the **2nd Inv-Battery** connector.

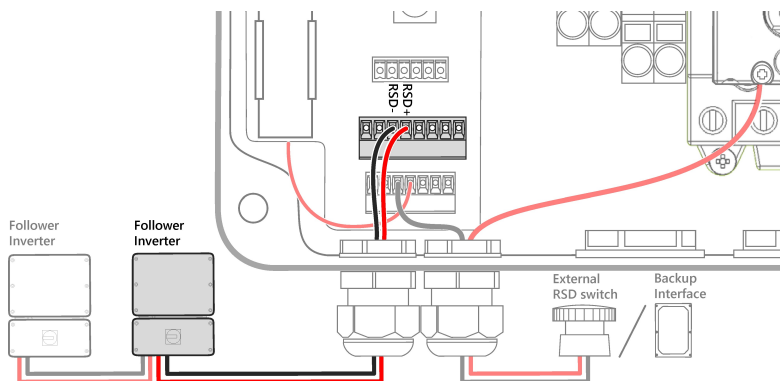

3. Pass the RSD+ and RSD- wires through Communication Gland 1 and connect them to a Follower inverter as shown above:
 - RSD+ to the Safety Switch
 - RSD- to the Backup Interface connector
4. Connect additional Follower inverters in the same way.

Connecting multiple inverters via RS485

Before connecting multiple inverters, make sure your inverters' firmware version supports this feature. For further information, contact SolarEdge support.

You can add inverters to your system to increase on-grid and backup power production. Up to two additional Single phase inverters with HD-Wave technology or Home Hub inverters may be connected to a single Home Hub inverter.

If a battery and Backup Interface are installed, the AC output from the additional inverters must be connected to the Backup Interface. Use a circuit breaker (CB-UPG-xx- 01) available from SolarEdge. For more information, refer to the Backup Interface Installation Guide.

When connecting multiple inverters, use the following cable types:

- **Communication** - 600V CAT6 or higher communication cable with individually shielded twisted pairs and an overall foil or braided shield, with conductor size between 0.2–1 mm² (approximately AWG 24–16).

To connect an additional Home Hub inverter

1. Connect the Leader inverter to the Backup Interface, as explained in [Connecting the Backup Interface \[39\]](#).
2. In both inverters, pass the communication cable through Communication Gland 2.
3. In the Follower inverter, connect the cable to the **2nd Inv RS485** connector.

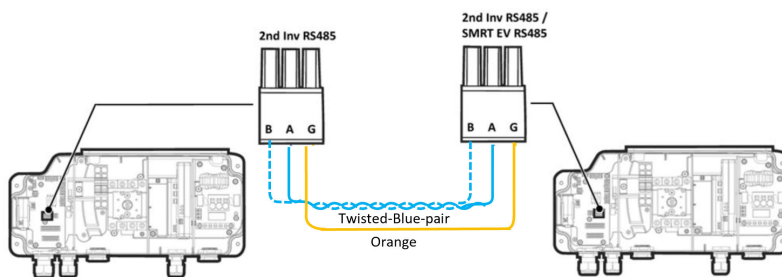

4. In the Leader inverter, connect the cable to either the **2nd Inv RS485** connector or the **SMRT EV RS485** connector.
5. Tug on the cables lightly to make sure they are properly connected.
6. Close the communication glands to a torque of 50in·lbf.

To connect an additional HD-Wave inverter:

1. In the HD-Wave inverter, connect one end of the communication cable to the **RS485-1** connector on the communication board. For more information, refer to the *HD-Wave inverter Installation Guide*.
2. Pass the other end of the communication through Communication Gland 2 of the Home Hub inverter.
3. Connect the cable to the **2nd Inv RS485** connector on the communication board.
4. Pull the cables lightly to make sure they are properly connected.
5. Close the communication glands to a torque of 50in·lbf.

Activating, commissioning and configuring the system

After installing the SolarEdge Home Hub system, you must perform activation and commissioning. To do this, use the SolarEdge Inverter SolarEdge Go mobile application.

During commissioning, you need to:

- Select the country grid name
- Pair the Power Optimizers to the Inverter.
- Configure Monitoring communications
- Add and configure all installed devices, such as batteries, home backup interface, meters, EV chargers, etc.

During commissioning, you also need to set the grid parameters and add Backup voltage information if relevant.

Before starting activation and commissioning, verify that all the communication hardware is properly connected. For communication options, refer to [Setting Up \[50\] Communication with the Monitoring Platform \[50\]](#).

Before arriving on site, download the SolarEdge Go application to your mobile device from the App Store or from Google Play.

You need an internet connection for one-time registration and login.

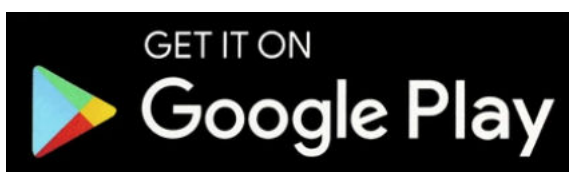

Activating the system

During system activation, a Wi-Fi connection is created between the mobile device and the inverter, and the inverter firmware is updated if necessary.

Before activation

1. Download, register (first time only) and login to SolarEdge Go on your mobile device.
2. Verify that you have the latest version of the application.
3. Power on all applicable connected devices (battery, Energy Meter, Backup Interface) so that the inverter can detect them.

To activate the inverter

1. Turn on the AC circuit breaker on the main distribution panel.
2. Turn on the DC Disconnect Switch (if applicable).
3. Open SolarEdge Go and follow the on-screen instructions.
4. Scan the inverter's QR code.
5. Hold the P/1/0 switch at the P position for 2 seconds and release.

SolarEdge Go creates a Wi-Fi connection, updates the inverter firmware and activates the inverter.

Commissioning the system

The following links explain how to commission and configure inverter settings for a Single Stock Keeping Unit (SKU) in SolarEdge Go:

- [Single SKU Residential Inverter Guidelines Application Note.](#)



- [SolarEdge Single SKU Home Hub inverter Commissioning Training Video.](#)



- [Single SKU Service and RMA Application Note](#)



- [SolarEdge Single SKU Home Hub Inverter RMA Process Training Video](#).

**NOTE**

Menus in the SolarEdge Go application may vary depending on your system type.

Power Control

The Grid Control option may be disabled. Enabling it opens additional options in the menu.

To set power export limitation use the Energy Manager option as described in the [Export Limitation Application Note](#).

For the P-Q diagram, refer to this [Technical Note](#).

**NOTE**

SolarEdge inverters with "Grid Support" functionality (as marked on the inverter certification label) are compliant with UL 1741 Supplement A. The functionality is built into the inverter, and no additional external device is required.

Verifying activation and commissioning

To verify correct activation and commissioning

1. Select **Information** and verify that the correct firmware version is installed on each inverter.
2. Select **Status** and verify that the inverter is operating and producing power.
3. Verify that additional configurations were properly set by viewing the relevant **Status** screens.
4. Verify that the green inverter LED is lit and steady.

Your SolarEdge Solar harvesting system is now operational.

Configuring communication with other devices

If some devices were not auto-detected during system activation, make sure they are turned on and search for them again under "Device Manager".

To set up communication with an external Energy Meter

If the Backup Interface is installed as part of your system, configure the Backup Interface's meter as follows:

1. In SolarEdge Go select **Commissioning > Site Communication**
2. In the RS485-1 screen, select **Add Modbus Device > Meter**.
3. Set the Energy Meter's **CT Rating** according to the CT specifications. If the CT rating value returns to 0, check communication with the CT.
4. Select **Meter 2 > Meter Function > Export+Import (E+I)**.

To set up communication with the Smart EV Charger

1. In SolarEdge Go select **Commissioning > Site Communication**.
2. Configure the Home Hub inverter to be the leader by selecting **RS485-2 > Protocol SolarEdge > SolarEdge Leader**.
3. Configure the Smart EV Charger to be the follower by selecting **RS485-2 > Protocol > Follower Detect**.

Enabling StorEdge applications

This section describes configuring your system to use StorEdge applications. Before enabling StorEdge applications, finish the battery installation and configuration (refer to the battery installation guide).

Backup Power applications

Produced power is stored in the battery to be used during power outages. When the grid voltage is down, the Backup Interface automatically switches to Backup mode, disconnects from the grid, and the Home Hub inverter supplies power to the backed-up loads. This application requires connection to the Backup Interface and backed-up loads. Loads are pre-selected or the entire home may be connected to back up.

The application can be used in one of two ways:

- **Backup-only** – energy stored in the battery is discharged for backup power only, that is, when there is no power from the grid
- **Backup with Smart Energy Management**– use some of the battery energy for backup power, and the rest for maximizing self-consumption (MSC) or charge/ discharge profile programming (for time of use arbitrage) applications.

The Backup application can be used whether PV modules are installed at the site or not. The backup function is disabled by default and can be enabled for on-grid only application, if backup is not needed.

To start using StorEdge applications, you first need to enable the Backup Configuration functionality, which is disabled by default. If Backup Configuration is disabled, the system uses battery energy in the following cases:

- When PV production is not sufficient for MSC.

- When using one of the charge/discharge profiles that requires battery discharge.

In these cases stored energy is not used to back up the loads in case of a power outage.

To enable Backup Configuration

In SolarEdge Go select **Commissioning > Power Control > Energy Manager > Backup Configuration > Backup > Enable**.

After the Backup Configuration is enabled, the Backup Interface is automatically configured.

To enable a StorEdge application

1. Select **Power Control > Energy Manager > Energy Control**.
2. Select one of the following applications:
 - **Backup only** - Set the system to supply power to backed-up loads only in case of a power outage.
 - **Time of use** - Set a charge/discharge profile and the level of charging the battery from AC.
 - **Maximum Self Consumption (MSC)** - Set the system to maximize self- consumption and the level of stored energy to be reserved for backup.

Reporting and monitoring installation data

Monitoring the site requires connecting the inverter to the monitoring platform using any of the wired or wireless options available from SolarEdge. Refer to [Setting Up \[50\]](#) [Communication with the Monitoring Platform \[50\]](#).

The Monitoring platform

The Monitoring platform provides enhanced PV performance monitoring and inverter yield assurance through immediate fault detection and alerts at the panel, PV array and system level.

The platform enables you to:

- View the latest performance of specific components.
- Find under-performing components such as PV panels by comparing their performance to that of other components of the same type.
- Pinpoint the location of alerted components using the physical layout.

You can access site information in the Monitoring platform, including up-to-date information, viewed in a physical or logical view:

- **Logical Layout:** Shows a schematic tree-layout of the components in the system, such as: inverters, Power Optimizers, PV arrays, panels, meters and sensors, as well as their

electrical connectivity. This view enables you to see which panels are connected in each PV array and which PV arrays are connected to each inverter.

- **Physical Layout:** Provides a bird's eye view of the actual placement of panels on the site and allows you to pinpoint issues to the exact location of each panel on a virtual site map.

If you do not report the mapping of the installed Power Optimizers, the Monitoring platform displays the logical layout, indicating which Power Optimizers are connected to which inverter, but will not display PV strings or the physical location of Power Optimizers.

The Monitoring platform includes a built-in help system that guides you through the monitoring functionality. For more information, refer to the [SolarEdge Monitoring Platform](#).



Creating Logical and Physical layout using installation information

To display a logical layout, input the inverter serial number in the new site created in the Monitoring platform. When the communication between the inverter and the monitoring server is established, the logical layout is displayed.

To display a physical layout, you need to map the locations of the installed Power Optimizers. To map the locations, use one of the methods described in the next sections.

Designer

Designer recommends inverter and Power Optimizer selection per site size and enables report generation. You can create a project in Designer and export the site design with the PV array layout to the monitoring platform.

For more information, refer to [SolarEdge Designer](#).





Mapper Application

Use the Mapper smart phone application to scan the Power Optimizer and inverter QR codes and create a virtual map of a PV site for enhanced monitoring and easier maintenance. Features of Mapper include:

- Simple on-site registration of new systems.

- Creating, editing and verifying system physical layout.
- Scanning and assigning the Power Optimizer serial number to the correct panel in the system physical layout.

For detailed information, refer to the following videos:

Mapper demo movie.	
Creating and editing sites using Mapper	

Physical Layout Editor

If you are a registered installer:

Access the Monitoring platform site creation page .	
---	--

If you have not yet signed up, create an account [here](#).

Fill out all required information in the screen, which includes information about your installation, as well as details about its logical and physical mapping.

Setting up communication with the Monitoring platform

The inverter sends the following information to the Monitoring platform:

- Power Optimizer information received via the DC power lines (the PV output circuit).

- Inverter information.
- Information for any of the other connected devices.

This chapter describes how to set up communication between:

- The inverter and the Monitoring platform through the Internet (wired/wireless).
- Multiple inverters for a leader-follower configuration.

Communication setup is not required for power harvesting; however it is needed for using the Monitoring platform.



CAUTION

Before connecting the communication cables, make sure that the ON/OFF/P switch at the bottom of the inverter is OFF, the DC Safety Unit is turned OFF and the AC is turned OFF.

When configuring the communication parameters, make sure that the ON/OFF/P switch on the inverter is OFF, and the AC is turned ON.

ATTENTION!

Lors de la connexion des câbles de communication, assurez-vous que l'interrupteur MARCHE/ARRÊT à la base de l'onduleur soit en position ARRÊT, le sectionneur DC est éteint et le CA est en position ARRÊT. Lors de la configuration des paramètres de communication, assurez-vous que l'interrupteur MARCHE/ARRÊT soit en position ARRÊT, et le CA est en position MARCHE.

Communication options

The following types of communication can be used to transfer the monitored information from the inverter to the Monitoring platform. Only communication products offered by SolarEdge are supported.

Ethernet

Ethernet is used for a LAN connection.

RS485

RS485 is used for the connection of multiple SolarEdge devices on the same bus in a leader-follower configuration. RS485 can also be used as an interface to external devices, such as meters and third-party data loggers.

Wireless Gateway, Wireless Repeater/s

The Wireless Gateway collects inverter data using a dedicated Wi-Fi connection and connects to the monitoring platform with the help of a home router. Wireless Repeater(s) extend the Wi-Fi signal range between the Wireless Gateway and inverter. Wireless Gateway and Wireless Repeaters can be purchased separately from SolarEdge.

<p>For more information, refer to this Installation Guide.</p>	
--	--

Cellular

You can use a cellular connection to connect one or more devices (depending on your data plan) to the monitoring platform.

The Cellular Plug-in is supplied with a user manual, which should be reviewed prior to connection.

<p>Refer to this Installation Guide.</p>	
--	--

Communication connectors

Opening for cable size (diameter)	Connection type
4–6 mm	Shielded twisted-pair RS485 wiring
6–8 mm	Typical U.S. CAT6/CAT6A shielded cable
2 - 4mm, with cut	Antenna cable for wireless communication

The communication board has the following connectors:

- Standard RJ45 terminal block for Ethernet connection
- RS485 connector

The SolarEdge Wi-Fi antenna, Home Network, or Cellular Plug-ins can be connected to the communication board for additional wireless options.

Removing the inverter cover

To remove the inverter cover

1. Turn off the AC circuit breaker on the main distribution panel.
2. Turn off the inverter ON/OFF/P switch and wait 5 minutes for the internal capacitors to discharge.
3. Open the Allen screws of the inverter cover and carefully pull the cover away horizontally before lowering it.



CAUTION

When removing the inverter cover, make sure not to damage the internal components. SolarEdge will not be held responsible for any components damaged as a result of incautious cover removal.

ATTENTION!

Lors du retrait du couvercle, assurez-vous de ne pas endommager les composants internes. SolarEdge ne peut être tenue pour responsable des composants endommagés à la suite d'une imprudence dans le retrait du couvercle.

Removing the Connection Unit cover

1. Turn off the AC circuit breaker on the main distribution panel and the safety switch (if applicable).
2. Open the DC Safety Unit cover.
3. Release the four Allen screws and remove the cover.



CAUTION

When removing the DC Safety Unit cover, make sure not to damage the internal components. SolarEdge will not be held responsible for any components damaged as a result of incautious cover removal.

ATTENTION!

Lors du retrait du couvercle, assurez-vous de ne pas endommager les composants internes. SolarEdge ne peut être tenue pour responsable des composants endommagés à la suite d'une imprudence dans le retrait du couvercle.

Creating an Ethernet (LAN) connection

You can use an Ethernet connection to connect the inverter to the monitoring platform through a LAN.

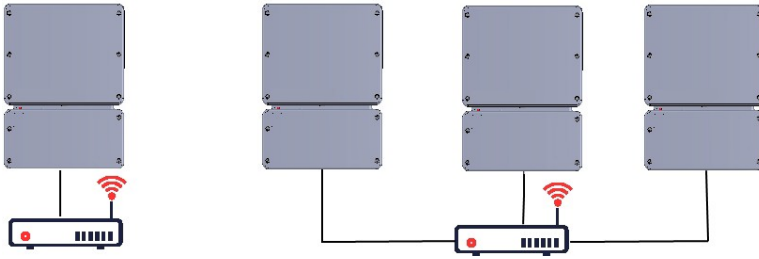

Ethernet cable specifications:

- Cable type: shielded CAT6 Ethernet cable
- Maximum distance between the inverter and the router :100m (330ft).



NOTE

For cables longer than 10m (33ft) in areas where there is a risk of Induced voltage surges from lightning, SolarEdge recommends using an external surge protection device.

For details refer to this [Technical note](#).



To connect the Ethernet cable

1. Remove the inverter cover as described above.
2. Open Communication Gland 1.



CAUTION

The gland includes a rubber waterproof fitting, which must be used to ensure proper sealing.

ATTENTION!

Le cote interne du gland contient une rondelle qui doit être utilisée pour une bonne étanchéité.

3. Remove the plastic seal from one of the large openings.

4. Remove the rubber fitting from the gland and insert the CAT6 cable through the gland and through the gland opening in the inverter.
5. Push the cable into the cut opening of the rubber fitting.

CAT6 standard cables have eight wires (four twisted pairs), as shown in the diagram below. Wire colors can differ from one cable type to another. You can use either wiring standard, if both sides of the cable have the same pin-out and color-coding.

RJ45 Pin #	Wire Color ¹	10Base-T Signal	100Base-TX Signal
	T568B	T568A	
1	White/Orange	White/Green	Transmit+
2	Orange	Green	Transmit-
3	White/Green	White/Orange	Receive+
4	Blue	Blue	Reserved
5	White/Blue	White/Blue	Reserved
6	Green	Orange	Received-
7	White/Brown	White/Brown	Reserved
8	Brown	Brown	Reserved

¹The inverter connection does not support RX/TX polarity change. Supporting crossover Ethernet cables depends on the switch capabilities.

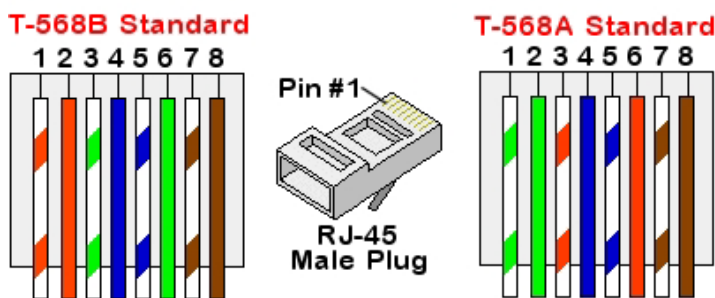

6. Use a pre-terminated cable to connect through Communication Gland 1 to the RJ45 connector on the inverter's communication board or, if using a spool of cable, connect as follows:
 - a. Insert the cable through the gland.
 - b. Remove the cable's external insulation using a crimping tool or cable cutter and expose eight wires.
 - c. Insert the eight wires into an RJ45 connector.
 - d. Use a crimping tool to crimp the connector.

- e. Connect the Ethernet connector to the RJ45 port on the communication board.
7. For the switch/router side, use a pre-terminated cable or use a crimping tool to prepare an RJ45 communication cable: Insert the eight wires into the RJ45 connector in the same order as above.
8. Connect the cable's RJ45 connector to the RJ45 port of the Ethernet switch or router. You can connect more than one inverter to the same switch/router or to different switches/routers, as needed. Each inverter sends its monitored data independently to the SolarEdge monitoring platform.
9. The inverter is configured by default to connect via ethernet.
 - a. Make sure the ON/OFF/P switch is OFF.
 - b. Turn ON the AC to the inverter by turning ON the circuit breaker on the main distribution panel.
 - c. Turn ON the Connection Unit.

**WARNING**

ELECTRICAL SHOCK HAZARD. Do not touch uninsulated wires when the inverter cover is removed

- d. Configure the connection as described in [Communication](#).

**NOTE**

If your network has a firewall, you may need to configure it to enable the connection to the following address:

Destination Address: **prodssl.solaredge.com**

TCP Port: **443** (for incoming and outgoing data)

Verifying the connection

After connecting and configuring a communication option, perform the following steps to check that the connection to the Monitoring platform has been successfully established.

1. Commission the inverter as describe in [Activating, Commissioning, and Configuring the system](#). [44]
2. In SolarEdge Go, in the **Configuration** screen, tap **Status**.
3. In the **Summary** section, under **Server Comm.**, make sure **S_OK** is displayed together with the selected communication option.
4. Scroll down to the **Communication** section and check that the communication options are correct.

Appendix A: Errors and troubleshooting

This chapter describes troubleshooting general system problems. For further assistance, contact SolarEdge Support.

Identifying errors

Errors may be indicated in various system interfaces: On the inverter bottom panel, a red LED indicates an error. In the monitoring platform and SolarEdge Go, errors are displayed with codes.

For more information on the codes displayed for error and warning messages, refer to this [Addendum](#).

This document describes errors that appear in SolarEdge Go, Monitoring, and LCD (for applicable inverters). To identify the error types, use the methods described below.



To identify the error type using the inverter LEDs:

1. Hold the ON/OFF/P switch in the **P** position for **2 seconds** and release it.
2. Observe the LED lights and use the following table to identify the error.

For more information, refer to [LED Indicators](#).

Error Type	Inverter LED Color and State		
	Red	Green	Blue
Arc detected	ON	OFF	OFF
Isolation or RCD problem	Blinking	OFF	OFF
Grid error	OFF	ON	OFF
High temperature	OFF	Blinking	OFF
Pairing failed	OFF	OFF	ON
Other issue	OFF	OFF	Blinking

To identify the error type using the monitoring platform:

1. Open the site dashboard and click the **Layout** icon.

2. Right-click the inverter and select **Info** from the menu. The inverter details window displays.
3. Click the **Errors** tab. The list is displayed.

Home Hub Inverter troubleshooting

Malfunction	Description or Possible Cause	Corrective Action
Battery SOE (state of energy) is below 10%, while solar power is being produced	Continuous discharge; no charging	Perform a battery self-test as explained in Running a Battery self-test . If the battery self-test is successfully passed, contact SE support.
No power to backed-up loads during a power outage	The loads are not backed up.	<p>Check the following:</p> <p>The inverter is producing power.</p> <p>The Backup function is enabled, as explained in Enabling StorEdge Applications [47]. No error messages are displayed in SolarEdge Go. Backed-up load circuit breakers are on.</p> <p>The Backup Interface is in the Backup mode (the green LED on the Backup Interface is continuously ON).</p>
The inverter does not turn on.	External shutdown is on.	<p>If an external shutdown switch is installed, make sure it is in the ON position.</p> <p>If no external shutdown switch is installed, make sure the external shutdown short circuit jumper in the Backup Interface is installed.</p>
Battery self-test failed	Wrong battery connections	Make sure the DC cables, RS485 and En wires between the battery and inverter are correctly connected.
Error 3×6B	Battery communication error	<p>Make sure the RS485 and En wires between the battery and inverter are correctly connected.</p> <p>Make sure the battery is correctly configured, as explained in Configuring Communication with other Devices [46]</p>
Error 3×6C	Battery internal error	Contact SolarEdge support.

Troubleshooting Communication

Troubleshooting Ethernet (LAN) Communication

The errors and their troubleshooting procedures are detailed in the following table:

Error Message	Possible Cause and Troubleshooting
LAN cable disconnected	Physical connection fault. Check the cable pin- out assignment and cable connection.
No DHCP	IP settings issue. Check the router and inverter configuration. Consult your network IT support staff.
Configure Static IP or set to DHCP	
Gateway not responding	Ping to router failed. Check the physical connection to the switch/router. Check that the link LED at the router/switch is lit (indicating phy-link). If OK, contact your network IT. Otherwise replace the cable or change it from cross to straight connection.
No Internet connection	Ping to google.com failed. Connect a laptop and check for internet connection. If internet access is unavailable, contact your IT admin or your internet provider.

Troubleshooting RS485 communication

- If the message **RS485 Leader Not Found** appears in the Status screen, check the connections to the leader device and fix if required.
- If after follower detection the number of followers displayed for the leader under **RS485- > Follower Detect** is lower than the actual number of followers, refer to the following application note to identify missing followers and troubleshoot connectivity problems:

https://knowledge-center.solaredge.com/sites/kc/files/troubleshooting_undetected_RS485_devices.pdf



Additional troubleshooting

1. Check that the modem or hub/router is functioning properly.
2. Check that the connection to the internal connector on the communication board is properly done.
3. Check that the selected communication option is properly configured.

4. Use a method independent of the SolarEdge device to check whether the network and modem are operating properly. For example, connect a laptop to the Ethernet router and connect to the Internet.
5. Check whether a firewall or another type of network filter is blocking communication.

Power Optimizer troubleshooting

Malfunction	Possible Cause and Corrective Action
Pairing failed	<p>Power Optimizers are in shade.</p> <p>If you connected the inverter to the monitoring platform, retry pairing remotely when there is adequate sunlight. Make sure to leave the inverter ON/OFF/P switch ON and that S_OK appears in the status screen.</p>
PV string Voltage is 0V	<p>Power Optimizer/s output is disconnected.</p> <p>Connect all Power Optimizer outputs.</p>
PV string voltage not 0V but lower than number of Power Optimizers	<p>Some Power Optimizer/s are not connected in the PV string.</p> <p>Connect all Power Optimizers.</p>
	<p>Some panel/s are not connected properly to Power Optimizer inputs.</p> <p>Connect the panels to the Power Optimizer inputs.</p>
	<p>PV string reverse polarity.</p> <p>Check PV string polarity using a voltmeter and correct if needed.</p>
PV string voltage is higher than the number of Power Optimizers.	<p>Extra Power Optimizer(s) connected in the PV string.</p> <p>Check if an extra Power Optimizer is connected in the PV string. If not – proceed to next solution.</p>
	<p>A panel is connected directly to the PV string, without a Power Optimizer (not applicable to smart panels).</p> <p>Verify that only Power Optimizers are connected in the PV string and that no panel outputs are connected without a Power Optimizer. If the problem persists, proceed to the next step.</p>

Malfunction	Possible Cause and Corrective Action
<div style="border: 1px solid #ccc; padding: 10px; background-color: #f9f9f9;">  <p>WARNING</p> <p>If the measured voltage is too high, the installation may not have a safe low voltage. PROCEED WITH CARE! A deviation of +/-1% per PV string is reasonable.</p> <p>AVERTISSEMENT!</p> <p>Si la tension mesurée est trop haute, la tension basse de sécurité pourrait manquer dans l'installation. REDOUBLEZ DE PRECAUTION. Une déviation de +/-1% par string est raisonnable.</p> </div>	<p>Power Optimizer/s malfunction.</p> <ol style="list-style-type: none"> 1. Disconnect the wires connecting the Power Optimizers in the PV string. 2. Measure the output voltage of each Power Optimizer to locate the Power Optimizer that does not output 1V safety Voltage. If a malfunctioning Power Optimizer is located, check its connections, polarity, panel, and Voltage. 3. Contact SolarEdge Support. Do not continue before finding the problem and replacing the malfunctioning Power Optimizer. If a malfunction cannot be bypassed or resolved, skip the malfunctioning Power Optimizer, thus connecting a shorter PV string.

Support contact information

If you have technical problems concerning SolarEdge products, please contact us:



<https://www.solaredge.com/us/service/support>

Before contacting support, make sure to have the following information at hand:

- Model and serial number of the product in question.
- The error indicated on the SolarEdge Go mobile application, on the monitoring platform, or by the LEDs, if there is such an indication.
- System configuration information, including the type and number of panels connected and the number and length of strings.
- The communication method to the SolarEdge server, if the site is connected. The product's software version as it appears in the status screen.

Appendix B: UL 9540 Multi-part ESS components

Energy Storage System model numbers		
DCD-1PH-US-P4H-F-I, DCD-1PH-US-P4H-F-N, DCD-1PH-US-P6H-F-I, DCD-1PH-US-P6H-F-N, DCD-1PH-US-P3H-F-I, DCD-1PH-US-P2H-F-I, DCD-1PH-US-P3H-F-N, DCD-1PH-US-P2H-F-N.		
Permitted UL 9540 ESS equipment list		
Equipment	Manufacturer	Models
Grid Interactive Inverter	SolarEdge	SE3000H-US, SE3800H-US, SE5000H-US, SE5700H-US, SE6000H-US, SE7600H-US, SE9600H-US, SE10000H-US, SE11400H-US
Storage Connection Unit	SolarEdge	DCD-1PH-US-P4H-F-I, DCD-1PH-US-P4H-F-N, DCD-1PH-US-P6H-F-I, DCD-1PH-US-P6H-F-N, DCD-1PH-US-P3H-F-I, DCD-1PH-US-P2H-F-I, DCD-1PH-US-P3H-F-N, DCD-1PH-US-P2H-F-N
Backup Interface (Optional)	SolarEdge	BI-E, BI-N
Battery	SolarEdge	BAT-10K1P
Energy Storage Systems and Equipment [ANSI/CAN/UL 9540:2023 Ed.3]		