



Installation Guide

SolarEdge TerraMax Inverter

PN: SE330K-XXXXXXXX & SE300K-XXXXXXXX

For Europe, APAC, and South Africa

Version 1.5

Disclaimers

Important Notice

Copyright © SolarEdge Inc. All rights reserved.

No part of this document may be reproduced, stored in a retrieval system, or transmitted, in any form or by any means, electronic, mechanical, photographic, magnetic or otherwise, without the prior written permission of SolarEdge Inc.

The material furnished in this document is believed to be accurate and reliable. However, SolarEdge assumes no responsibility for the use of this material.

SolarEdge reserves the right to make changes to the material at any time and without notice. You may refer to the SolarEdge website (www.solaredge.com) for the most updated version.

All company and brand products and service names are trademarks or registered trademarks of their respective holders.

Patent marking notice: see <http://www.solaredge.com/patent>

The general terms and conditions of delivery of SolarEdge shall apply.

The content of these documents is continually reviewed and amended, where necessary. However, discrepancies cannot be excluded. No guarantee is made for the completeness of these documents.

The images contained in this document are for illustrative purposes only and may vary depending on product models.

This manual describes the installation of the SolarEdge TerraMax Inverter Installation Guide. Read this manual before you attempt to install the product, and follow the instructions throughout the installation process. If you are uncertain about any of the requirements, recommendations, or safety procedures described in this manual, contact SolarEdge Support immediately for advice and clarification. The information included in this manual is accurate at the time of publication. However, the product specifications are subject to change without prior notice. In addition, the illustrations in this manual are meant to help explain system configuration concepts and installation instructions. The illustrated items may differ from the actual items at the installation location.

Revision History

Version 1.5 (March 2026)

Added Cable Guidelines.

- Version 1.4 - Changed torque values. Changed optimizer's 'cable' to 'wire' to comply with the Inflation Reduction Act.
- Version 1.3 - Added wire lug compatibility.
- Version 1.2 - Change of product name to SolarEdge TerraMax Inverter.
- Version 1.1 - Removed PG wires next to the DC bus-bar. Version 1.0 - Initial release.

Table of Contents

Disclaimers	1
Important Notice	1
Revision History	2
Version 1.5 (March 2026)	2
HANDLING AND SAFETY INSTRUCTIONS	6
Safety Symbols Information	6
Chapter 1: System Overview	9
The SolarEdge TerraMax Inverter	10
Combiner Box	11
The H1300 Power Optimizer	11
Designer	12
Monitoring Platform	12
SetApp	12
Installation Tools and Material List	13
Chapter 2: Inverter Overview	14
Inverter Features	14
DC Disconnect Switch	15
ON/OFF/P Switch	15
Indication LEDs	17
AC Panels	19
DC Panel	20
Communication Compartment	20
Communication Cable Glands	20
Cooling Fans	20
Chapter 3: Installing the Power Optimizers	21
General Description	21
Safety	22
Package Contents	23
Installation Guidelines	23
Mounting the Power Optimizers	25
Connecting the PV module to the Power Optimizer	26
Connecting Power Optimizers in PV Strings	27
String Length Guidelines	27
Inter-Block Wiring Guidelines	29
In-Block Wiring Guidelines	29
DC Cable Guidelines – from Optimizers String to Combiner Box	30
Homerun DC Cable Guidelines - from Combiner box to Inverter	31
MV/HV Cable Wiring and Layout Constraints	31
String Tests	32
Verifying Proper Power Optimizers Connection on a String	32
Chapter 4: Installing the Inverter	34

Mounting the Inverter.....	34
Dimensions.....	35
Installation Location and Positioning.....	35
Clearance Requirements.....	35
Inverter Transport and Storage.....	37
Shipping Box Contents.....	37
Identifying the Inverter.....	37
Mounting Bracket.....	38
Mounting the Inverter Before Wiring is Laid Down.....	39
Mounting the Inverter when Wiring is Already Laid Down.....	40
Connecting PV Strings and Arrays.....	42
Connecting AC to the Inverter.....	43
Wiring Guidelines.....	44
Grid Connection Information.....	45
Connecting Communication.....	48
Connecting the CAN / RS-485 Communication Between Inverters / RS-485 Between Inverter and Third Party Device.....	50
Connecting the LAN Communication Between the LAN Router and the Leader Inverter.....	52
Selecting a Residual Current Device (RCD).....	53
Chapter 5: Activating, Commissioning, and Configuring the System.....	54
Activating the Installation.....	55
Commissioning and Configuring the Installation.....	55
Setting Country and Grid.....	56
Pairing.....	56
Communication.....	57
PowerControl.....	57
Verifying Proper Activation and Commissioning.....	57
Central Commissioning.....	58
DC Commissioning.....	58
Reporting and Monitoring Installation Data.....	58
The Monitoring Platform.....	58
Creating Logical and Physical Layout using Installation Information.....	59
Appendix A: Errors and Troubleshooting.....	61
Identifying Errors.....	61
Power Optimizer Troubleshooting.....	62
Troubleshooting Communication.....	63
Troubleshooting Ethernet (LAN) Communication.....	63
Troubleshooting CAN Bus Communication.....	64
Additional Troubleshooting.....	64
Isolation Fault.....	64
Appendix B: Maintenance.....	65
Routine Maintenance of the System.....	65

Visual Inspections.....	66
Ground Connection.....	66
Fan Maintenance	66
Wire Connections.....	67
General Cleaning.....	68
Monitoring the Solar System Performance.....	69
Appendix C: SafeDC™	70
Appendix D: Technical Specifications.....	71

HANDLING AND SAFETY INSTRUCTIONS

Safety Symbols Information

The following safety symbols are used in this document. Familiarize yourself with the symbols and their meaning before installing or operating the system.



WARNING!

Denotes a hazard. It calls attention to a procedure that, if not correctly performed or adhered to, could result in **injury or loss of life**. Do not proceed beyond a warning note until the indicated conditions are fully understood and met.



CAUTION!

Denotes a hazard. It calls attention to a procedure that, if not correctly performed or adhered to, could result in **damage or destruction of the product**. Do not proceed beyond a caution sign until the indicated conditions are fully understood and met.



NOTE

Denotes additional information about the current subject.



IMPORTANT SAFETY FEATURE

Denotes information about safety issues.

Disposal requirements under the Waste Electrical and Electronic Equipment (WEEE) regulations:



Discard this product according to local regulations or send it back to SolarEdge.



WARNING!

To reduce the risk of injury, read all instructions in this document.



WARNING!

SolarEdge Inverter Installation Guide must be followed to maintain the integrity of the PV hazard control system. SolarEdge Power Optimizers and/or inverters may only be replaced with SolarEdge Power Optimizers and/or inverters. Third-party equipment is not compatible with SolarEdge equipment.



WARNING!

Using this equipment in a manner not specified by SolarEdge in this document may impair the protection provided by this equipment.

WARNING!

**WARNING!**

The inverter cover should be opened only after shutting off the inverter, by moving the ON/OFF/P switch to the OFF(0) position. This disables the DC voltage inside the inverter. Wait five minutes before opening the cover. Otherwise, there is a risk of electric shock from energy stored in the capacitors.



P = Program/Pair (Momentary toggle)
1 = ON
0 = OFF

**WARNING!**

Before operating the inverter, ensure that the inverter AC power cable and wall outlet are grounded properly. This product must be connected to a grounded, metal, permanent wiring system, or an equipment-grounding conductor must be run with the circuit conductor

**WARNING!**

Opening the inverter and repairing or testing under power must be performed only by qualified service personnel familiar with this inverter.

**WARNING!**

High DC Voltage on PV strings at night when Potential Induced Degradation (PID) The rectifier / Volt-Ampere Reactive (VAR) control function is active. DO NOT touch any component or perform any maintenance operation on the PV strings.



High DC Voltage on PV strings at night when the Potential Induced Degradation (PID) rectifier / Volt-Ampere Reactive (VAR) control function is active. DO NOT touch any component or perform any maintenance operation on the PV strings.

**WARNING!**

Do not touch the PV panels or any rail system connected when the inverter switch is ON, unless grounded.

**WARNING!**

SafeDC complies with IEC60947-3 when installing the system with a worst-case SafeDC voltage (under fault conditions) < 120V.

The worst case voltage is defined as: $V_{oc, max+} (PV \text{ string Length}-1)*1V$, where:

- $V_{oc, max}$ = Maximum V_{oc} (at lowest temperature) of the PV modules in the PV string (for a PV string with multiple modules, use the max value)
- PV string Length = number of Power Optimizers in the PV string

**CAUTION!**

This unit must be operated according to the technical specification datasheet provided with the unit.

CAUTION!

HEAVY OBJECT. To avoid muscle strain or back injury, use proper lifting techniques and, if required, a lifting aid.

NOTE

Use PV modules rated according to IEC 61730 class A.

NOTE

The symbol  appears at grounding points on the SolarEdge equipment. This symbol is also used in this manual.

NOTE

The following warning symbols appear on the inverter warning label:



Risk of electric shock



Risk of electric shock from energy stored in the capacitor. Do not remove cover until 5 minutes after disconnecting all sources of supply.



Hot surface – To reduce the risk of burns, do not touch.



Caution, risk of danger

CAUTION!

The inverter is only allowed to be installed in a closed electrical operating area.

Chapter 1: System Overview

SolarEdge Large Scale PV Plants Solution is a part of SolarEdge's grid services solution, which enables cloud-based, real-time, aggregate control, management, and reporting of distributed energy resources for the creation of solar power plants.

Virtual power plants are interconnected and decentralized energy networks that offer improved grid reliability, services, stability, and costs. They can help utilities, energy retailers, and large fleet solar owners to meet energy supply shortages and maintain grid stability.

This SolarEdge power harvesting solution is designed to maximize the power output from any type of solar Photovoltaic (PV) installation while reducing the average cost per Watt. *Figure 1* shows and the following sections describe the components of the SolarEdge power harvesting system. Figure 1 shows SolarEdge Large Scale PV Plants Solution.

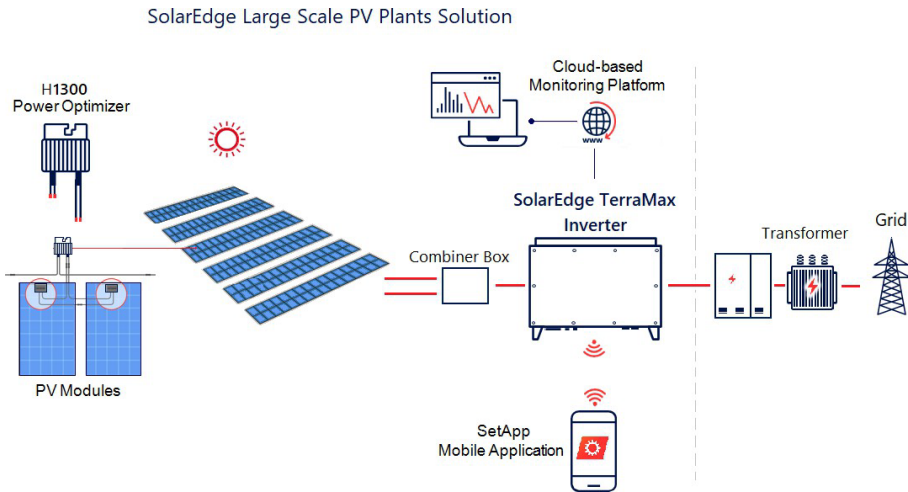

Figure 1 The SolarEdge Large Scale PV Plants Solution

The SolarEdge TerraMax Inverter

The SolarEdge TerraMax Inverter (referred to as 'inverter' in this manual) efficiently converts DC power from the PV modules into AC power that can be fed into the main AC service of the site and from there to the grid. The inverter also receives the monitoring data from each Power Optimizer and transmits it to the SolarEdge Monitoring platform (requires a landline connection to the Internet).

A chain of up to 13 inverters can be set to communicate together over CAN bus and connect to a single transformer. Each inverter operates independently and continues to work in case others stop operating.

When setting a chain of inverters, the inverter that manages the communication interface to the internet is called the Leader, and the rest are Followers.

Figure 2 Shows the SolarEdge TerraMax Inverter



Figure 2 SolarEdge TerraMax Inverter

Combiner Box

NOTE



The combiner box is not part of SolarEdge's offering and should be purchased separately.

A combiner box is an enclosure that aggregates the DC output of multiple solar panels and combines them into a single DC circuit. It contains fuses, disconnect switches, and wiring to combine the outputs of two PV arrays into a single larger output, routed to the inverter.

The H1300 Power Optimizer

The SolarEdge H1300 Power Optimizer is a device that connects to two PV modules and optimizes and maximizes power harvesting performance by performing module-level maximum power point tracking (MPPT). The Power Optimizers regulate the PV string Voltage at a constant level, regardless of PV string length and environmental conditions. It also provides module-level monitoring and safety features such as automatic voltage shutdown. The H1300 Power Optimizer is designed only for SolarEdge inverters and is used for commercial and large field installations.

Figure 3 shows the H1300 Power Optimizer



Figure 3 The H1300 Power Optimizer

The Power Optimizers include a safety Voltage mechanism that automatically reduces the output of each Power Optimizer to 1 Vdc in the following cases:

- During fault conditions
- The Power Optimizers are disconnected from the inverter
- The inverter ON/OFF/P switch is turned OFF
- The inverter AC breaker is turned OFF

Each power optimizer also transmits module performance data over the DC power line to the inverter.

Designer

SolarEdge Designer is a powerful tool and a user-friendly web application that simplifies solar energy system design. It offers an intuitive interface and advanced optimization features to help professionals create efficient PV designs. With accurate simulation algorithms and integration with SolarEdge products, it maximizes system performance. The application also enables financial analysis and supports collaboration.

Monitoring Platform

SolarEdge Monitoring Platform is a user-friendly solution for monitoring and managing solar energy systems. The platform presents real-time monitoring, historical data analysis, alerting capabilities, and remote troubleshooting features.

The platform empowers users to optimize energy production, detect and resolve issues efficiently, and make data-driven decisions to enhance the performance and efficiency of their solar installations.

For more information on the Monitoring Platform, refer to the C&I One User Guide, available at https://utility.solaredge.com/hub/ci_one_user_guide.pdf

SetApp

SolarEdge SetApp is a mobile application developed and designed to simplify the process of commissioning and configuring SolarEdge inverters and power optimizers by providing an intuitive and efficient interface for installers.

With SetApp, installers can easily access and configure SolarEdge inverters and power optimizers through their smartphone or tablet. The user-friendly app guides installers step-by-step through the entire commissioning process, ensuring that each component is properly connected and configured for optimal performance.

This eliminates the need for complex manual setup procedures and significantly reduces the time and effort required for system installation.

Installation Tools and Material List

Standard tools can be used during the installation of the SolarEdge system.

The following recommended tools are required for installation:

- Allen screwdriver for 4mm screw type for the inverter cover, inverter cover screws
- Allen screwdriver for M5/M6/M8 screw types
- Standard flat-head screwdrivers set
- Non-contact Voltage detector
- Cordless drill (with a torque clutch) or screwdriver and bits suitable for the surface on which the inverter and Power Optimizers will be installed. Use of an impact driver is not allowed.
- MC4 crimping tool
- Ratchet torque & extension for 35 N*m, 18 N*m
- Deep A/F 18mm and A/F17mm socket wrenches
- Torque screwdriver with extension for Allen bits 4.7 N*m, 3.9 N*m, 2.4 N*m, 1.2 N*m
- Ring/Lug terminals crimping tool
- Wire cutters
- Wire strippers
- Multimeter

For secondary grounding:

- Ring/lug terminal crimper tool for the Ground wire
- Ring/lug terminal
- Serrated washer
- Grounding screw
- Two washers

Chapter 2: Inverter Overview

Inverter Features

Figure 4 shows the SolarEdge TerraMax Inverter features

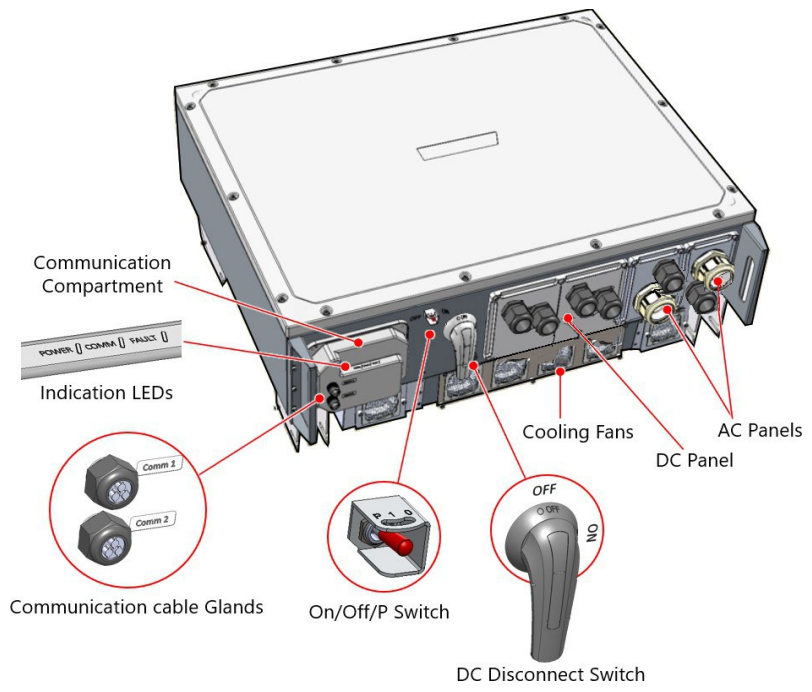

Figure 4 SolarEdge TerraMax Inverter features

DC Disconnect Switch

The DC Disconnect Switch is a manually operated safety switch for disconnecting the DC power of the SolarEdge system. The switch is used to disconnect the solar array from the inverter in case of fire or to lower the chance of damage to the inverter caused by weather.

WARNING!

When the inverter is OFF (for example, during maintenance), it must be locked to prevent a safety hazard:



Pull the white tab out away from the blue handle and insert a padlock through one of the holes.



AVERTISSEMENT!

Lorsque l'onduleur est éteint (par exemple pendant la maintenance), il doit être verrouillé pour éviter tout risque de sécurité :

Retirez la languette blanche de la poignée bleue et insérez un cadenas dans l'un des trous.

ON/OFF/P Switch

Figure 5 shows the ON/OFF/P switch of the SolarEdge TerraMax Inverter.

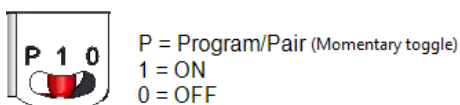

Figure 5 SolarEdge TerraMax Inverter features

- ON (1) – Turning this switch ON (after Power Optimizer pairing) starts the operation of the Power Optimizers, enables power production, and allows the inverter to begin exporting power to the utility grid.
- OFF (0) – Turning this switch OFF reduces the Power Optimizer Voltage to a low safety Voltage and inhibits exportation of power. When this switch is OFF, the Inverter control circuitry remains powered up.
- P – Holding the switch pressed in the P position allows performing the following functions:

P Position duration	Function	Comments
The switch moved to P for less than 5 seconds , then released.	<ul style="list-style-type: none"> ■ Displays production information for 5 seconds on the SetApp screen. ■ Displays error type indications (if exist) for 5 seconds. ■ Activates the Wi-Fi access point for connecting to the SolarEdge Inverter SetApp 	While the switch is in P, all LEDs are ON
The switch moved to P for more than 5 seconds , then was released.	Starts pairing	

WARNING!



The inverter cover should be opened only after shutting off the inverter, by moving the ON/OFF/P switch to the OFF(0) position. This disables the DC voltage inside the inverter. Wait five minutes before opening the cover. Otherwise, there is a risk of electric shock from energy stored in the capacitors.

Indication LEDs

LED indication consists of color and state (on/ off/ blinking⁽¹⁾/ flickering⁽²⁾/alternating⁽²⁾).

The LEDs indicate different system information, such as errors or performance.

Figure 6 shows the Indication LEDs of the inverter.

Generally, the main LED indications are:

- COMM. ON - the inverter is communicating with the monitoring platform
- POWER ON - the system is producing
- POWER blinking - AC is connected, but the system is not producing power
- FAULT ON - system error

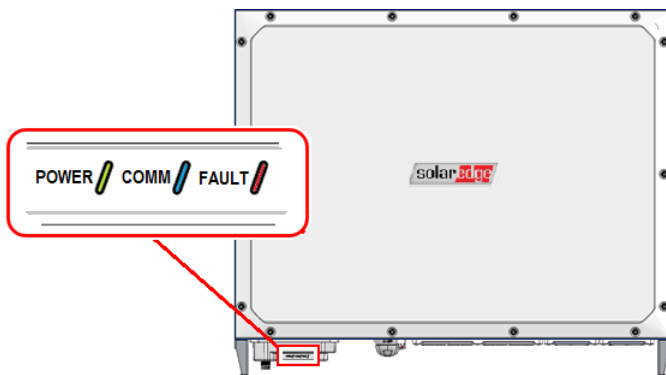







Figure 6 Indication LEDs

-
- (1) Blinking = Turns ON and OFF for the same duration
 - (2) Flickering = Turns ON for 100 mS and turns OFF for 5 seconds
 - (3) Alternating = Alternate LEDs flash

Indication	ON/ OFF/ P switch position	POWER LED	COMM. LED	FAULT LED	Comment
Power Optimizers not paired		Blinking	 S_OK: ON  No S_OK: OFF	OFF	S_OK: ON means that communication with the Monitoring Platform is established. S_OK: OFF means that there is no communication with the Monitoring Platform.
Pairing	ON (1)	Blinking	Blinking	Blinking	
Wake-up/ Grid Monitoring		Blinking	Blinking	OFF	
System Producing		ON	 S_OK: ON  No S_OK: OFF	OFF	
Night mode (no production)		Flickering	 S_OK: ON  No S_OK: OFF	OFF	
Inverter is OFF (Safe DC - optimizer's output voltage is 1V, DC voltage is below 50V)	OFF (0)	Blinking		OFF	

Indication	ON/ OFF/ P switch position	POWER LED	COMM. LED	FAULT LED	Comment
Inverter is OFF (DC not safe - - DC voltage is above 50V)		Blinking	<div style="display: flex; flex-direction: column; gap: 5px;"> ■ S_OK: ON</div>	Blinking	
Inverter configuration or reboot	ON / P	ON	ON	ON	
Inverter firmware upgrade	ON / P	Alternating	Alternating	Alternating	The upgrade process can take up to 20 minutes
Error	Any	ON/ OFF/ Blinking/ Flickering	ON/ OFF / Blinking/ Flickering	ON	Refer to <i>the Errors and Troubleshooting section</i>

The following table describes the production percentage of AC information by indication LEDs, color, and ON/OFF/P switch position.

Indication	ON/OFF/P switch position	LED color			Comment
		Green	Blue	Red	
Percentage of AC Production: 0 - 33 %	ON (1)	ON	OFF	OFF	This indicates power production as a percentage of rated peak AC output power
Percentage of AC Production: 33 - 66 %		OFF	ON	OFF	
Percentage of AC Production: 66 - 100 %		ON	ON	OFF	

AC Panels

- **AC 1 Cable Gland:** AC cable gland for grid connection
- **AC 2 Cable Gland:** AC cable gland for grid connection
- **Protective Earth (PE) Wire Entry:** Two PE glands for connecting Protective Earth (PE) wires

DC Panel

To connect wires, follow the writing shown next to each wire on the panel.

- **DC Wire Glands:** DC wire glands for up to two PV array connections.
- **Protective Earth (PE) Wire Entry:** PE gland for connecting Protective Earth (PE) wire.

Communication Compartment

The communication compartment comprises the communication board of the inverter. The communication board is equipped with the following communication options:

- **Controller Area Network (CAN)** is a communication protocol used for real-time data exchange between up to 13 inverters. CAN communication includes messaging, error detection, and prioritization information.
- **RS-485** is a communication protocol used for real-time data exchange with third-party devices such as meters or local controllers.
- **LAN** is a communication protocol used for connecting the inverter to a remote monitoring platform via an internet LAN router.

Communication Cable Glands

Two communication glands on the communication compartment for communication and antenna cables.

Cooling Fans

Six cooling fans for removing warm air from the inverter, improving the power generation.

Chapter 3: Installing the Power Optimizers

General Description

The inverter is designed to directly connect to up to two PV arrays via an external combiner box.



NOTE

To enable the system operation in full capacity, connect at least 14 strings to the inverter.

A combiner box is an electrical distribution box that may also host DC circuit breakers. The main purpose of the box is to combine multiple parallel strings of PV modules in the system into a single DC output. This DC output is then connected to a single DC input in the inverter. The SolarEdge TerraMax Inverter has two DC inputs. Therefore, up to two combiner boxes can be connected to each inverter.

The combiner box should be installed and connected before connecting to the inverter. This simplifies the commissioning of the inverter by allowing testing and servicing of the inverter.

SolarEdge's fixed input Voltage architecture enables parallel PV strings to be of different lengths. Therefore, they do not need to have the same number of Power Optimizers, as long as the difference between the shortest and longest string, connected to the same inverter, is no more than five Power Optimizers.

Figure 7 shows an example of up to 13 TerraMax inverters (1 Leader and 12 Followers), of TerraMax 4MW In-block and Inter-block configurations with combiner boxes and PV strings.

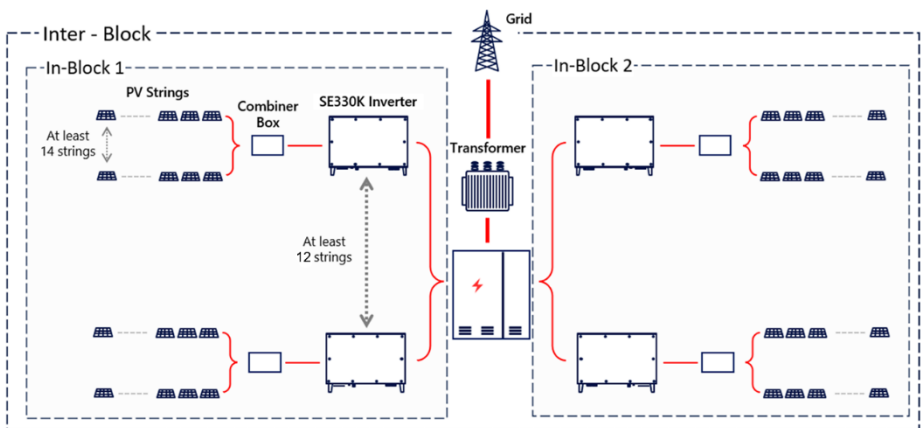

Figure 7 In-block and Inter-block site configurations

Safety

The following notes and warnings apply when installing the Power Optimizers.

WARNING!



When modifying an existing installation, turn OFF the inverter ON/OFF/P switch, DC Disconnect Switch, and the AC circuit breaker on the main AC distribution panel. Wait five minutes before opening the cover. Otherwise, there is a risk of electric shock from energy stored in the capacitors.

WARNING!



Input and output MC4 connectors are not watertight until mated. Open connectors should be mated to each other or plugged with appropriate watertight caps.

CAUTION!



Power Optimizers are IP68/NEMA6P rated. Choose a mounting location where Power Optimizers will not be submerged in water.

CAUTION!



The Power Optimizer must be operated according to the technical specifications provided with the Power Optimizer.

CAUTION!



All PV modules must be connected to a Power Optimizer.

CAUTION!



If you intend to mount the Power Optimizers directly to the module or module frame, first consult the module manufacturer for guidance regarding the mounting location and the impact, if any, on module warranty. Drilling holes in the module frame should be done according to the module manufacturer's instructions.

CAUTION!



Installing a SolarEdge system without ensuring compatibility of the PV module connectors with the Power Optimizer connectors may be unsafe and could cause functionality problems such as ground faults, resulting in inverter shutdown. To ensure mechanical and electrical compatibility of the Power Optimizer connectors with the PV module connectors to which they are connected:

- Use identical connectors from the same manufacturer and of the same type on the Power Optimizers, PV modules, and the inverter DC input; or
- Verify that the connectors are compatible in the following way:
 - The PV module connector manufacturer should explicitly verify compatibility with the Power Optimizer connectors and the Inverter DC input connectors.

- A third-party test report by one of the listed external labs (TUV, VDE, Bureau Veritas UL, CSA, InterTek) should be obtained, verifying the compatibility of the connectors.

NOTE



Using incompatible connectors, as detailed above, will only result in voiding the warranty for issues related to connectors, but not for other optimizer issues.

REMARQUE

L'utilisation de connecteurs incompatibles, comme détaillé ci-dessus, entraînera uniquement l'annulation de la garantie pour les problèmes liés aux connecteurs, mais pas pour les autres problèmes d'optimisation.

IMPORTANT SAFETY FEATURE



SolarEdge Power Optimizers are safe as long as the Inverter is turned off. When the inverter is turned off or a Power Optimizer is disconnected, the output The voltage of the Power Optimizer drops to a safe level of 1V.

CARACTÉRISTIQUE DE SÉCURITÉ IMPORTANTE

Les optimiseurs de puissance SolarEdge sont sûrs tant que l'onduleur est éteint. Lorsque l'onduleur est éteint ou qu'un Power Optimizer est déconnecté, la tension de sortie du Power Optimizer chute à un niveau sûr de 1 V.

Package Contents

- Power Optimizers
- Installation Guide

Installation Guidelines

- For the minimum and maximum number of Power Optimizers in a PV string (PV string length), see the Power Optimizer datasheets. Refer to the Designer for PV string length verification. The Designer is available on the SolarEdge website at: <https://www.solaredge.com/products/installer-tools/designer#/>.
- SolarEdge allows the use of extension wires on the input side of the Power Optimizer when connected to a PV module or between two modules, as long as:
 - The total length of the round-trip wire, modules, and Power Optimizer input wires, do not exceed 16 m.
 - The connectors of the extension wires are identical to the connectors of the Power Optimizer.

- The Power Optimizer can be placed in any orientation.
- Position the Power Optimizer close enough to its module so that its wires can be connected and fastened to the mounting structure.
- Make sure to use Power Optimizers that have the required output and input conductor length.
- Completely shaded modules may cause their Power Optimizers to temporarily shut down. This will not affect the performance of the other Power Optimizers in the PV string if the minimum number of unshaded Power Optimizers connected in a PV string of modules is met. If, under typical conditions, fewer than the minimum Power Optimizers are connected to unshaded modules, add more Power Optimizers to the PV string.
- To allow for heat dissipation, maintain the following clearance (see Figure 8):

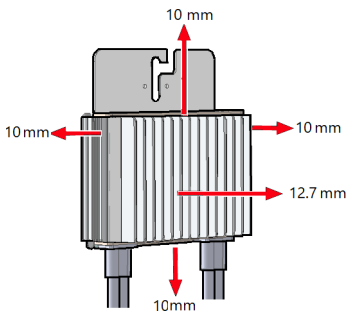

Figure 8 Clearance around the Power Optimizer for heat dissipation

- When installing PV modules in a confined space, ventilation measures may be required to ensure that the Power Optimizers do not exceed the maximum temperatures stated in their specifications.

Mounting the Power Optimizers

For each of the Power Optimizers⁽¹⁾:

1. Determine the Power Optimizer mounting location and use the Power Optimizer mounting brackets to attach the Power Optimizer to the support structure. It is recommended to mount the Power Optimizer in a location protected from direct sunlight.
2. If required, mark the mounting hole locations and drill holes.

CAUTION!



Drilling vibrations may damage the Power Optimizer and will void the warranty. Use a torque wrench or an electric drill with an adjustable clutch that meets the mounting torque requirements. *Do not* use impact drivers for mounting the Power Optimizer. *Do not* drill through the Power Optimizer or through the mounting holes.

⁽¹⁾Not applicable to smart modules

3. Attach each Power Optimizer to the rack using M6 or M8 stainless steel bolts, nuts, and washers or other mounting hardware. Apply a torque of 9-10 N*m.
4. Verify that each Power Optimizer is securely attached to the module support structure.
5. Record Power Optimizer serial numbers and locations, as described in *Reporting and Monitoring Installation Data* section.

NOTE



When installing the Power Optimizers before the PV Modules, protect the connectors from rain and dust by using the provided seals. A seal kit can also be purchased separately (Part ID: OPT-SEAL-100).

Connecting the PV module to the Power Optimizer

NOTE



Improper wiring may cause electrical faults in a PV system. To avoid electrical faults, verify proper locking of connectors and avoid cable tension and friction. Proper planning, materials, and installation reduce the risk of electric arcs, short-circuits, and ground faults in the PV system.

NOTE



Images are for illustration purposes only. Refer to the label on the product to identify the plus and minus input and output connectors.

NOTE



When connecting SolarEdge Power Optimizer to multiple PV modules, the modules must be of the same type.

NOTE



When connecting two modules to one Power Optimizer, both PV modules must be positioned at the same orientation and tilt angle.

For each Power Optimizer:

- Connect the Plus (+) output connector of the module to the Plus (+) input connector of the Power Optimizer (see Figure 9).
- Connect the Minus (-) output connector of the module to the Minus (-) input connector of the Power Optimizer.

CAUTION!



Do not sharply bend the DC wires. Keep proper bending radius to avoid cable breakage.

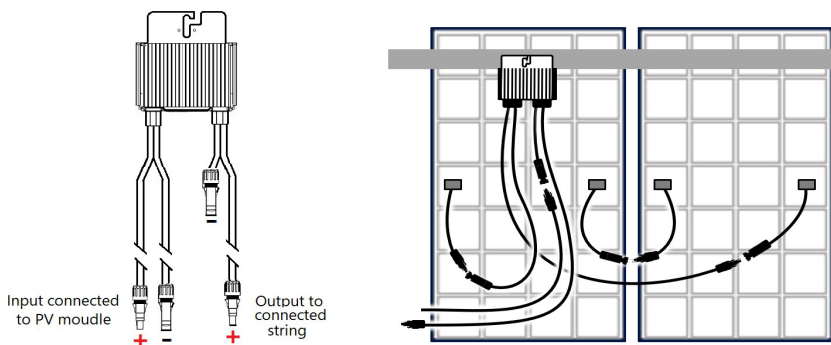

Figure 9 H1300 Power Optimizer Connectors

Connecting Power Optimizers in PV Strings

String Length Guidelines

Home-run Wires: You can construct parallel PV strings of unequal wire length, that is, the number of Power Optimizers in each PV string does not have to be the same. However, the longest string, connected to the same inverter, should not include more than five Power Optimizers than the shortest.

CAUTION!



When connecting three or more H1300 optimizer strings through a combiner box, SolarEdge recommends using a 30A fuse for each individual string to protect the system. However, be sure to check local electrical codes and regulations to determine the proper fuse sizing for your specific installation.



NOTE:

To minimize electromagnetic interference (EMI), make sure to minimize the distance between the positive and negative DC wires.



NOTE:

The DC input of each inverter must be separate and not shared with other inverters. Follow the inverter design rules as detailed in the Technical Specifications.

The maximum wire lengths in a solar system are shown in Figure 10.

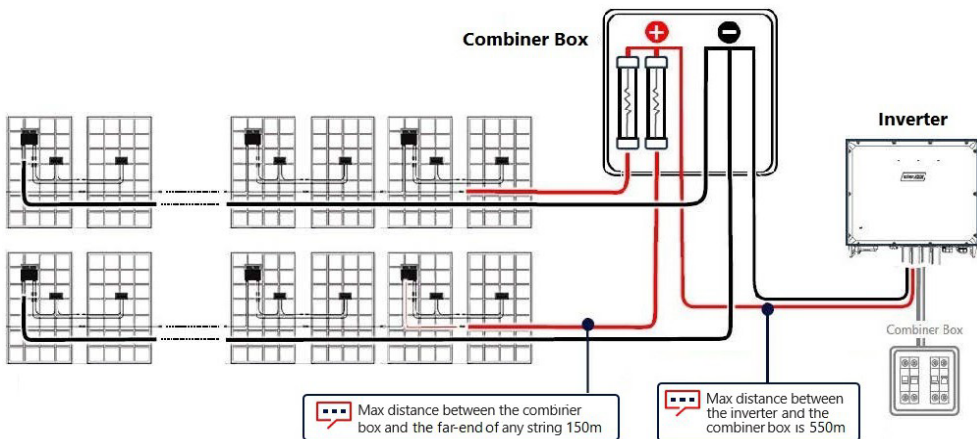

Figure 10 Maximum wire lengths

For the minimum and Maximum number of PV Panels and Power Optimizers in a string, refer to the Product Datasheet.

NOTE



Functional electrical earthing of DC-side negative or positive poles is prohibited because the inverter has no internal transformer. Grounding (earth ground) of module frames and mounting equipment of the PV array modules is acceptable.

→ To connect the Power Optimizers on a PV string:

1. Connect the Minus (-) output of the PV string's first Power Optimizer to the Plus (+) output connector of the PV string's second Power Optimizer.
2. To minimize electromagnetic interference (EMI), make sure to minimize the distance between the positive and negative DC wires. For detailed instructions, see: knowledge-center.solaredge.com/sites/kc/files/se-emi-performance-application-note.pdf
3. Connect the rest of the Power Optimizers to the PV string in the same manner (see Figure 11).

CAUTION!



Do not sharply bend the DC wires. Keep proper bending radius to avoid wire breakage.

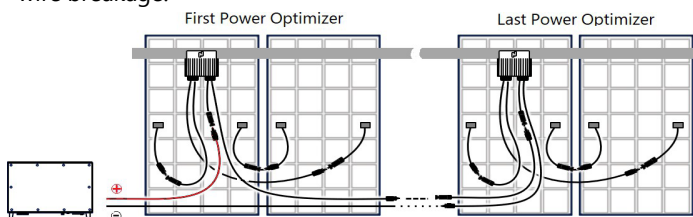

Figure 11 Power Optimizers connected in series

NOTE



If you install Power Optimizers before the PV Modules, protect the connectors from rain and dust by using the seals provided. Seal kits can be purchased separately (part ID: OPT-SEAL-100).

4. If you intend to monitor the installation, using the SolarEdge Monitoring platform, record the physical location of each Power Optimizer, as described in "Reporting and Monitoring Installation Data" on page 61.

WARNING!



Input and output connectors are not watertight until mated. Open connectors should be mated to each other or plugged with appropriate watertight caps.

Inter-Block Wiring Guidelines

The following guidelines apply to DC wires routed between two separate Inverter Blocks (Inter-Block DC wires, see Figure 7):

- **Case 1: Wires on Ground / Ducts:** DC wires routed on the ground or within grounded metal ducts shall maintain a minimum separation distance of 1 meter from the DC wires of an adjacent Inverter Block.
- **Case 2: Suspended Wires (Height-Dependent Clearance):** For wires located or hanging at a distance 'h' from a grounded surface, the separation distance from adjacent block DC wires shall be the greater of 1 meter or 10 times that height ('10h').
- **Overlap Exception** (for Case 1 and Case 2): Where maintaining the required minimum separation distance (1 meter or 10h, whichever is applicable) is unavoidable, the distance may be reduced in a specific section. This reduced-distance segment (the overlap) shall be kept as short as possible, and its total length shall be less than 7% of the total length of the shorter wire. The remainder of the wire run shall maintain the required minimum separation distance. (The total wire length is measured from the inverter to the furthest end of the string).

In-Block Wiring Guidelines

TerraMax is designed to include up to 12 inverters per "Block" (1x Leader + up to 11x Followers).

IMPORTANT NOTE



For Optimal design, Operations and Maintenance (O&M) simplicity, a "Block" should be regarded as a single group comprising Power, Programmable Logic Controller (PLC) Communication, and Modbus (CAN-bus) lines. While designs that separate Power and Modbus within a block are permitted, please consult SolarEdge for specific requirements and best practices regarding such configurations.

DC Cable Guidelines – from Optimizers String to Combiner Box

Figure 12 shows a conceptual TerraMax 12 Inverter block wiring diagram.

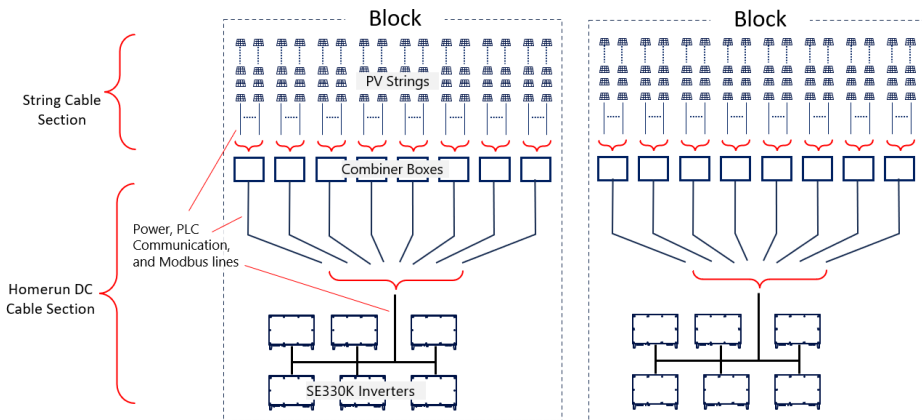

Figure 12 Conceptual Block TerraMax Wiring Diagram

Separation: String cables originating from each inverter must remain untangled and free of knots or twists with cables of other inverters within the same block.

Minimum Spacing: A minimum spacing of 5 cm must be maintained between the string cables of adjacent inverters (See Figure 13).

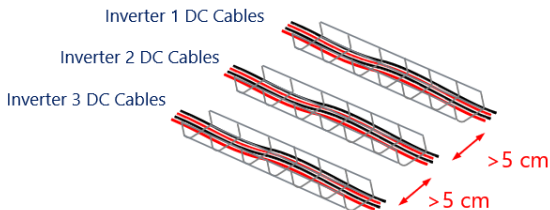

Figure 13 Minimum spacing between the DC strings of adjacent inverters

Conduit Routing: String cables belonging to the same inverter (DC+ and DC- cables) can be routed together in the same conduit (if conduits are used) (See Figure 14).

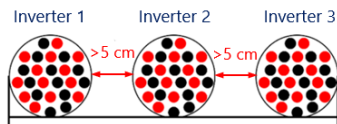

Figure 14 Conduit Routing of string wires

Homerun DC Cable Guidelines - from Combiner box to Inverter

Internal Integrity: Single inverter homerun DC cables (+/-) layout shall not twist or knot.

Inter-Inverter Spacing: Homerun cables shall not twist or knot between each other and must maintain at least 5 cm spacing between the cables of each adjacent inverter (See Figure 15).

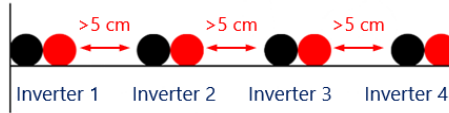

Figure 15 Minimum spacing between Inter-Inverter DC wires

MV/HV Cable Wiring and Layout Constraints

Distance between DC wires and Medium/High Voltage (MV/MV) cables:

The horizontal distance between any MV cables and DC wires must be more than 3 m (See Figure 16).

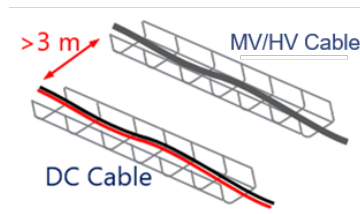

Figure 16 Horizontal distance between any MV/HV cables and DC wires

Vertical distance between any MV/HV cables and DC wires: The vertical distance between any MV/HV cables and DC wires must be more than 1 m (See Figure 17).

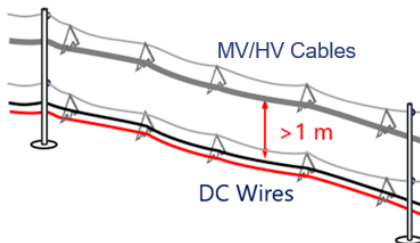

Figure 17 Vertical distance between MV/HV cables and DC wires

Vertical distance between any DC wires and grounded wires: In case wires are located/hang in a distance of 'h' from the grounded wire or surface, verify a distance of '10h' from the adjacent block DC wires (See Figure 18).

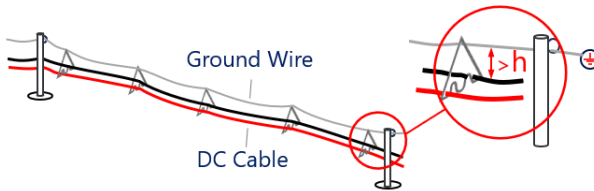

Figure 18 Vertical distance between any DC wires and grounded wires

String Tests

Verifying Proper Power Optimizers Connection on a String

When a module is connected to a Power Optimizer, the Power Optimizer outputs a safe Voltage of 1V ($\pm 0.1V$). Therefore, the total PV string Voltage should equal 1V times the number of Power Optimizers connected in series in a PV string. For example, if 24 Power Optimizers are connected in a PV string, then 24 Vdc should be produced (see Figure 19).

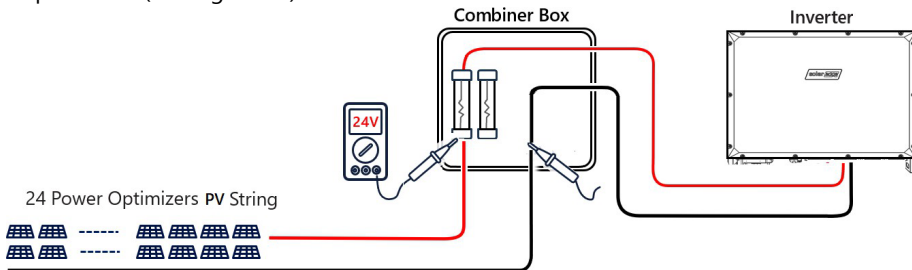

Figure 19 Verifying Proper Power Optimizers Connection on a String

Make sure the PV modules are exposed to sunlight during this process. The Power Optimizer will only turn ON if a PV module provides at least 2W.

In SolarEdge systems, due to the introduction of Power Optimizers between the PV modules and the inverter, the short circuit current I_{SC} and the open circuit voltage V_{OC} hold different meanings from those in traditional systems.

For more information about the SolarEdge system's PV string Voltage and current, refer to the V_{OC} and I_{SC} in *SolarEdge Systems Technical Note*, available on the SolarEdge website at:

https://www.solaredge.com/sites/default/files/isc_and_voc_in_solaredge_systems_technical_note.pdf

→ To verify proper Power Optimizer connection:

1. Verify that the DC Disconnect switch of the inverter is in the OFF position (See "Inverter Features " on page 14).
2. Measure the Voltage of each PV string individually before connecting it to the other PV strings or to the inverter. Verify correct polarity by measuring the PV string polarity with a Voltmeter. Use a Voltmeter with at least 0.1V measurement accuracy.



NOTE

Since the inverter is not yet operating, you may measure the PV string Voltage and verify the correct polarity on the DC wires.

For troubleshooting Power Optimizer operation problems, refer to Power Optimizer Troubleshooting section.

Chapter 4: Installing the Inverter

Mounting the Inverter

This section provides instructions for vertical mounting of the inverter on a metal construction or a wall.



CAUTION!

SolarEdge Inverters and Power Optimizers can be installed at a minimum distance of 50 m from the shoreline of an ocean or other saline environment, if there are no direct saltwater splashes on the inverter or Power Optimizer.

- Ensure a clear and safe workspace.
- Open the shipping box and remove the inverter from the shipping platform.



CAUTION!

The inverter weighs 163 kg. To prevent injuries and strain, never attempt to lift the shipping box by hand.

- Verify all components and check for damage.
- Lift the inverter using a forklift or a hoist. Handle and transport with care.
- Read the user manual and gather accessories.
- Store packaging materials for future use.
- For temporary storage of the inverter, keep it in a dry, well-ventilated area, away from potential hazards.

Dimensions

Figure 20 shows the dimensions of the inverter.

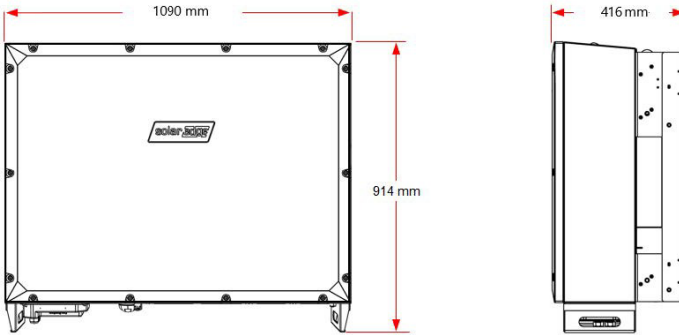

Figure 20 Inverter dimensions

Installation Location and Positioning

Figure 21 shows the allowed mounting positions of the inverter.

NOTE:



SolarEdge recommends keeping the inverter shaded and out of direct sunlight to prevent overheating, a reduction in power output, and premature wear of electrical components.



NOTE:

The Inverter position must be vertical to the ground with no tilt.

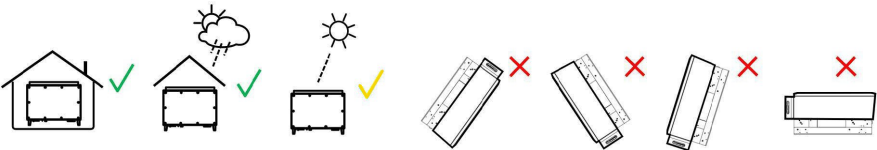

Figure 21 Location and position of the inverter

Clearance Requirements

To allow proper heat dissipation and prevent power reduction due to excessive temperature, ensure sufficient air circulation, and maintain minimum clearance between the inverter and other objects (See Figure 22).

It is recommended that the inverter be shaded to minimize direct sunlight exposure and heat absorption.

If shaded areas are unavailable, it is recommended to build a simple shade structure above the inverter to shield it from direct overhead sunlight.

In case any type of metal fencing is required, it is strongly recommended to use a mesh fence or metal beam construction that will allow proper airflow and heat dissipation.

CAUTION!



By installing the Inverters on a Centralized platform, all space clearances around the inverter must be followed. Vertical installation of inverters (one above the other) is prohibited.

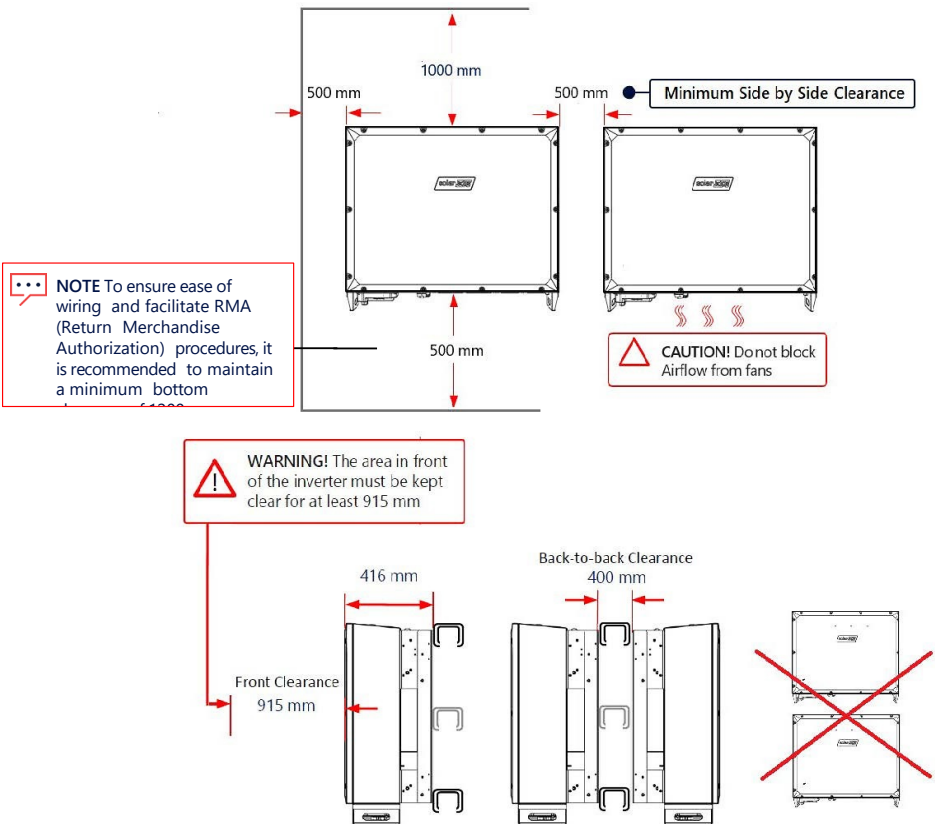

Figure 22 Inverter clearance requirements

Inverter Transport and Storage

Transport the inverter in its original packaging, facing up and without exposing it to unnecessary shocks. If the original package is no longer available, use a similar box that can withstand the weight of the inverter (refer to the inverter weight in the specification datasheet provided with the unit), has a handle system, and can be closed fully.

Shipping Box Contents

The shipping box of the inverter contains the following (See):

- Inverter
- Mounting Bracket Kit
- 4 Screw-in Handles (Optional)
- 2 Lifting Eye Bolts
- Documentation Bag

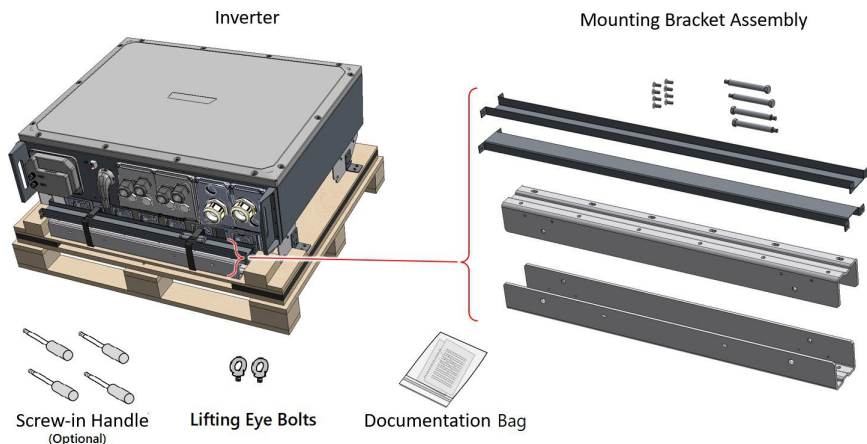

Figure 23 Inverter Package Contents

Identifying the Inverter

The stickers on the inverter specify the inverter's **Serial Number** and **Electrical Ratings**. When opening a site in the SolarEdge Monitoring Platform and when contacting SolarEdge support, provide the inverter's serial number.

Mounting Bracket

Assembling the Mounting Bracket

→ To assemble the mounting bracket:

1. Insert and secure the four Load Support Screws into the two Mounting Bars (See Figure 24). Torque the Load Support Screws to 8 N*m.
2. Use the left eight connecting screws to join the two Connecting Bars to the Mounting Bars. Torque the screws to 4.5 N*m.

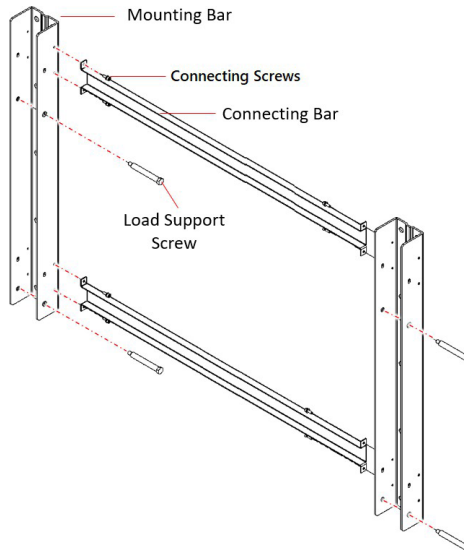

Figure 24 Assembling the Mounting Bracket

Installing the Mounting Bracket

→ To install the mounting bracket:

1. Level the mounting bracket of the inverter horizontally against the metal frame and mark at least eight drilling hole locations (see Figure 25).

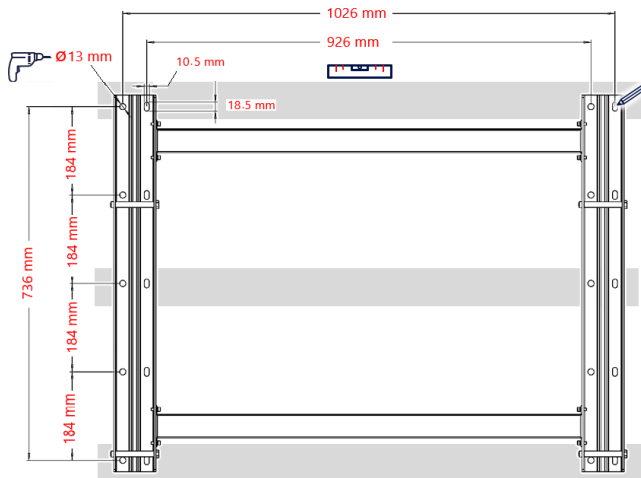

Figure 25 Marking the drilling holes in the mounting bracket

2. Drill at least eight Figure holes for mounting the bracket.
3. Position and secure the mounting bracket to the metal frame using at least eight bolts per fixture (At least four M8 bolts per mounting bar). Tighten the bolts all the way and verify that the mounting bracket is firmly attached to the metal frame.

Mounting the Inverter Before Wiring is Laid Down

→ To mount the inverter:

1. If optional screw-in handles are used, anchor the screw-in handle to any point at the inverter (see Figure 26).
2. Hoist the inverter towards the mounting bracket. Use the two lifting eye bolts on the inverter to securely lift the inverter. To avoid any stress on the inverter during lifting, always consider the center of gravity of the inverter while lifting.

CAUTION!



HEAVY OBJECT 163 kg. To avoid injury, use proper lifting techniques and, if required, a lifting aid. When lifting, balance the load to avoid stress.

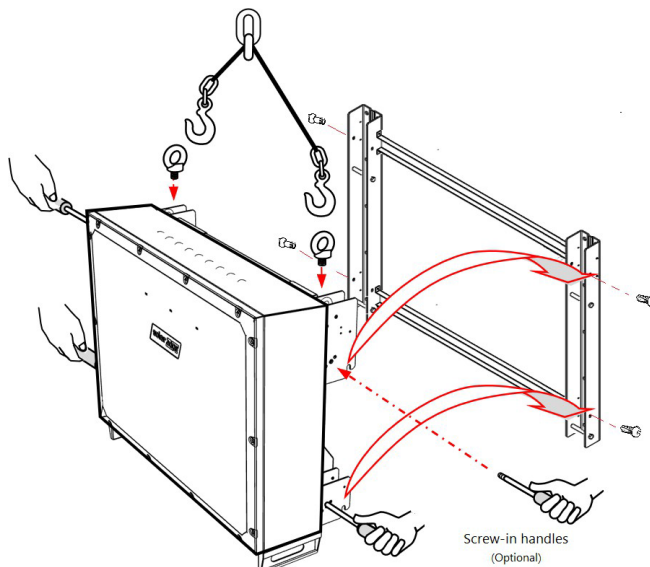

Figure 26 Mounting the inverter before wiring is laid down

3. Move the inverter to the destination by using the bottom handles as well as the Screw-in handle.
4. Align the four hangers on the back inverter enclosure with the mounting bracket and lower the inverter until it rests on the bracket evenly (see Figure 19).
5. Torque the four screws securing the inverter to the mounting bracket to 4.5 N*m.

Mounting the Inverter when Wiring is Already Laid Down

→ To mount the inverter:

1. If optional screw-in handles are used, anchor the screw-in handle to any point at the inverter (see Figure 27).
2. Loosen the screws securing the front panel of the inverter and remove the panel.
3. Hoist the inverter towards the mounting bracket. Use the two lifting eye bolts on the inverter to securely lift the inverter. To avoid any stress on the inverter during lifting, always consider the center of gravity of the inverter while lifting.

CAUTION!



HEAVY OBJECT 163 kg. To avoid injury, use proper lifting techniques and, if required, a lifting aid. When lifting, balance the load to avoid stress.

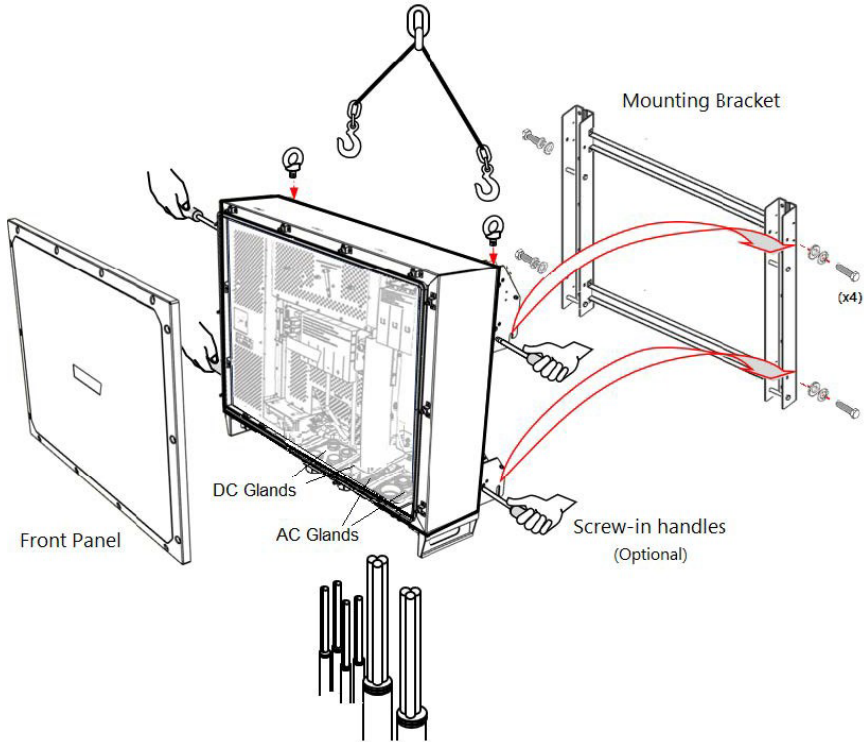

Figure 27 Mounting the inverter when the wiring is already laid down

4. Move the inverter to the destination by using the bottom handles as well as the Screw-in handle.
5. Lower the inverter, leading the AC and DC wires through the glands in the AC and DC panels at the bottom of the inverter.
6. Align the four hangers on the back inverter enclosure with the mounting bracket and lower the inverter until it rests on the bracket evenly.
7. Torque the four screws securing the inverter to the mounting bracket to 8.4 N*m.

Connecting PV Strings and Arrays

This section describes how to connect the inverter to the PV strings and PV arrays.

NOTE



Functional electrical Earthing of DC-side negative or positive poles is prohibited because the inverter has no transformer. Grounding (earth ground) of module frames and mounting equipment of the PV string modules is acceptable.

→ To unlock the Inverter and connect the PV strings to the DC terminal block of the inverter:

1. To unlock the inverter and enable power production, move the lock from SHIPMENT to OPERATION (see Figure 28).

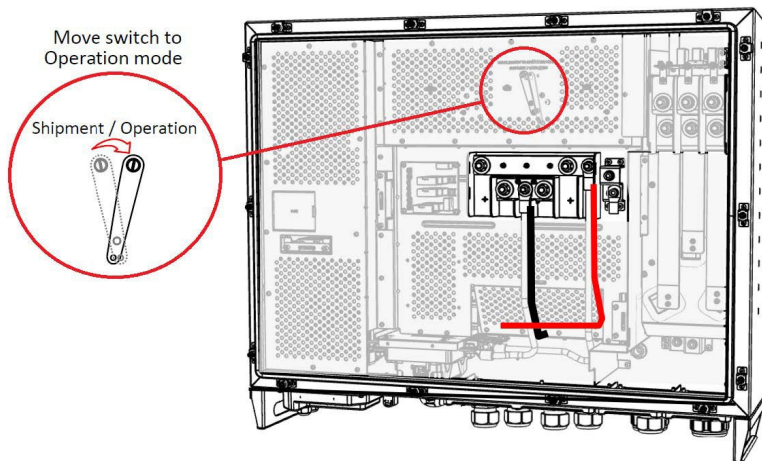

Figure 28 Unlocking the inverter

2. Remove the nut from the DC wire glands and lead the wires through the DC glands.
3. Strip the required length of insulation from the DC+ and DC- wires.
4. If aluminum wires are used, an oxidized layer on the wires could result in thermal issues, production loss, or damage to the inverter.

Perform the following steps before connecting lugs to aluminum wires:

- a. Remove oxide from the exposed wires with emery paper or a steel-wire brush.
 - b. Clean dust with a cloth and Isopropyl alcohol (IPA).
 - c. Coat wires with a designated antioxidant aluminum wire grease immediately after cleaning.
5. Crimp lugs on the DC wires.

**CAUTION!**

- For aluminum wires: Use Al/Cu (bi-metal) lugs or aluminum lugs with bi-metal washers. Place the bi-metal washer between the aluminum lug and the Inverter bus bar, copper side facing the bus bar.
- For copper wires: Use only copper tin-plated lugs.

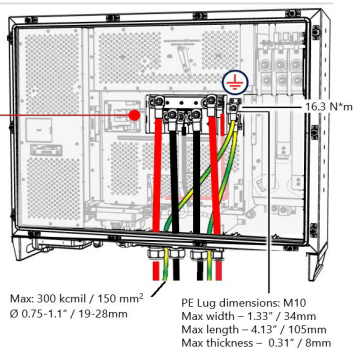
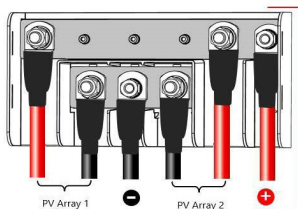
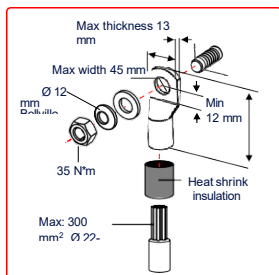

Figure 29 Connecting the DC wires to the Inverter

6. Connect the DC wires to the DC bus-bar according to the labels on the terminals. Tighten the nuts to 35 N*m (See Figure 29).

**CAUTION!**

DO NOT use an impact driver or any electrical tool to fasten the terminal screws.

7. Tighten DC glands to 20 N*m.
8. Place the cover of the DC terminal block in position and push until you hear a lock click.
9. Close the front cover of the inverter and fasten the screws to 3.9 N*m.

Connecting AC to the Inverter

This section describes how to connect the AC and ground to the Inverter.

The AC connections of 3 AC phases (L1, L2, and L3) and Ground. The AC connection of the inverter is spread across two cables, AC 1 and AC 2, to enable a flexible mechanical connection.

**WARNING!**

To avoid shock hazard conditions, the Protective Earth (PE) Ground wire must be connected to the inverter before connecting the AC wires.

Wiring Guidelines

- Use AC line wires with a maximum of 300 mm^2 cross-section conductor
- Use PE wire with a maximum of 150 mm^2 cross-section conductor
- Use wires compatible with local standards according to the inverter AC voltage.
- Use copper or aluminum wires with insulation rated for at least 90°C . Make sure to consider the maximum termination temperature at both ends of the conductor and to base the ampacity on the lower value.

NOTE



For more wiring information, refer to the SolarEdge Recommended AC Wiring Application Note, available on the SolarEdge website at

www.solaredge.com/sites/default/files/application-note-recommended-wiring.pdf

Grounding the Mounting Bracket

If required, ground the Mounting Bracket of the inverter as shown in *Figure 24*.

Use a grounding wire, a grounding screw, two washers, a ring terminal, and a serrated washer. Connect the grounding wire to the grounding point on the left or right side of the unit.

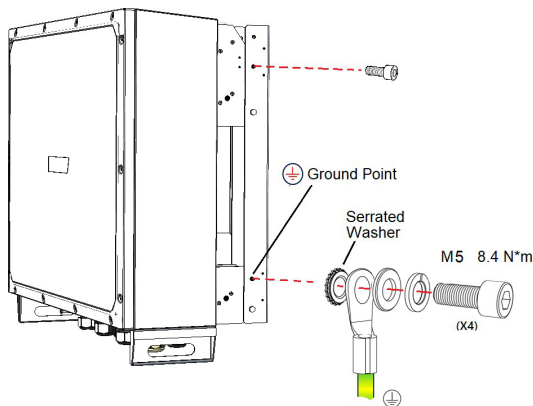

Figure 30 Grounding the mounting bracket of the inverter

Grid Connection Information

Before system installation, refer to the following table showing the short-circuit current in SolarEdge TerraMax Inverters:

Inom (A)	Ip (A)	1 RMS cycle (A)	3 RMS cycles (A)	Duration (ms)
275	592	217	236	150



WARNING!

The inverter must be protected by an over-current protection device (a circuit breaker or a fuse) with a recommended rating of 350 A per phase.

Over-current protection for the AC output must be provided by the installer.

For more wiring information, refer to the *SolarEdge Recommended AC Wiring Application Note*, available on the SolarEdge website at <http://www.solaredge.com/files/pdfs/application-note-recommended-wiring.pdf>.

→ To connect the AC wires to the inverter:

1. Release the Allen screws that secure the front cover to the inverter and carefully remove the cover (See Figure 31).

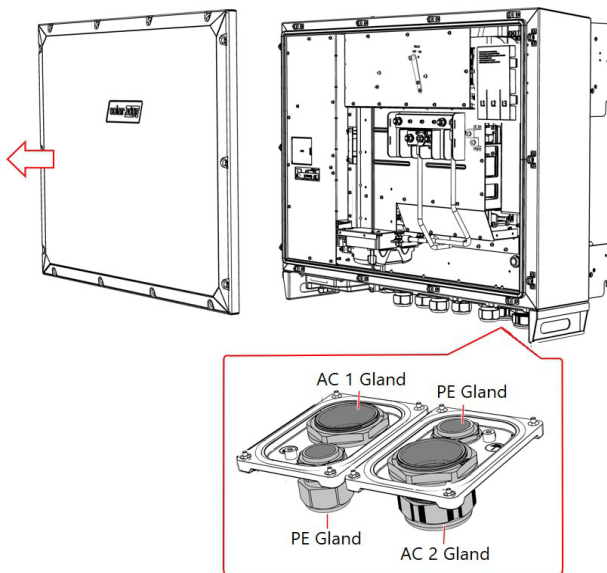

Figure 31 Inverter cover and AC panels

- Remove the nut from the Protective Earth (PE) gland and insert the PE wire through the PE gland (See Figure 31).
- Strip the required length of insulation from the PE wire, crimp a lug, and connect the wire to a PE terminal and tighten the screw to 16.3 N*m (see Figure 32).

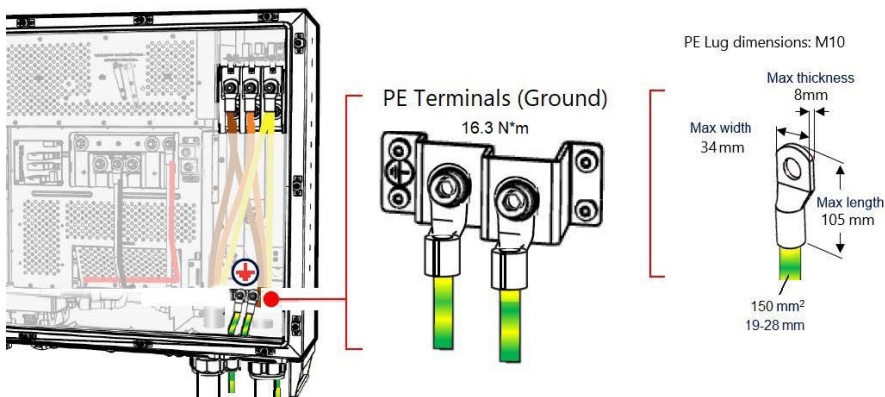

Figure 32 Connecting PE (Ground) to the Inverter

- Remove the Protective Cover from the AC terminal block.

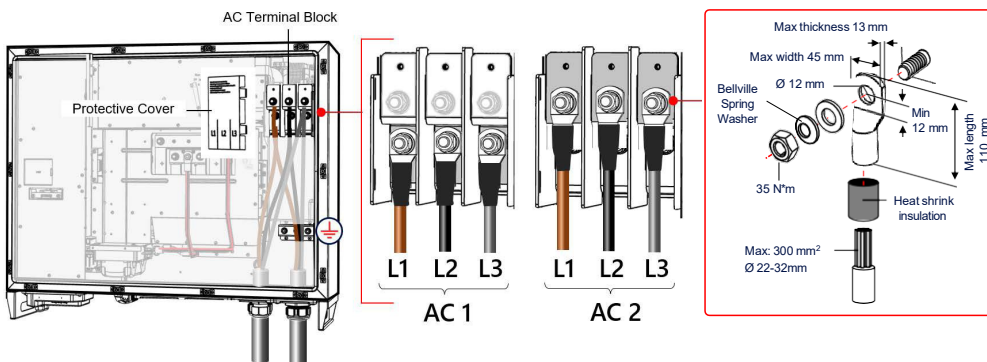

Figure 33 Connecting AC wires to the Inverter

- Remove the nut from AC 1 and AC 2 cable glands (see Figure 25) and lead the cables through the AC glands.
- Strip the required length of cable jacket from the AC 1 and AC 2 cables to expose the cable wires.

7. Strip the required length of insulation from the L1, L2, L3 wires of the AC 1 and AC 2 cables.
8. If aluminum wires are used, an oxidized layer on the wires could result in thermal issues, production loss, or damage to the inverter.

Perform the following steps before connecting lugs to aluminum wires:

- a. Remove oxide from the exposed wires with emery paper or a steel-wire brush.
 - b. Clean dust with a cloth and Isopropyl alcohol (IPA).
 - c. Coat wires with a designated antioxidant aluminum wire grease immediately after cleaning.
9. Crimp lugs on the wires of the AC 1 and AC 2 cables.



CAUTION!

- For aluminum cables: Use Al/Cu (bi-metal) lugs or aluminum lugs with bi-metal washers. Place the bi-metal washer between the aluminum lug and the Inverter bus bar, copper side facing the bus bar.
- For copper cables: Use only copper tin-plated lugs.

10. Connect the L1, L2, and L3 wires to the terminal block according to the labels on the terminals. Tighten the nuts to 35 N*m (see *Figure 27*).
11. Tighten the AC gland nut/caps to 30 N*m.
12. Tighten PE gland nut/caps to 11 N*m
13. Place the Protective Cover on the AC terminal block and push until you hear a lock click.
14. Close the front cover of the inverter and fasten the screws to 3.9 N*m in a crossed pattern.

Connecting Communication

In large solar installations, SolarEdge TerraMax Inverters are connected in a communication network to monitor system performance and identify any faults or issues.

The two common communication protocols used for inverter networks are CAN (Controller Area Network) and RS-485 (Modbus protocol).

The CAN network is used for linking up to 13 SolarEdge TerraMax Inverters. The maximum distance allowed between the first and last inverter is 750 m.

IMPORTANT NOTE!



Only SolarEdge TerraMax Inverters should be connected to the CAN bus network. **Do not connect** inverters or devices other than SolarEdge TerraMax Inverters to the CAN bus.

RS-485 is used to connect peripheral equipment such as meters, Power Plant Controller (PPC), or other third-party equipment. The maximum distance allowed between the inverter and a third-party device is 1000 m.

In a CAN network, one inverter acts as the Leader inverter. This Leader unit serves as the gateway to external monitoring and direct data through a connected LAN router and an internet link.

The other inverters in the system are Follower inverters, which report operational and production data back to the Leader inverter, linked to the same bus.

The CAN protocol uses a single, shielded twisted pair cable to connect the inverters in a daisy-chain layout. RS-485 networks also follow a daisy-chain design and utilize shielded twisted pair cabling. The CAN network requires proper line termination at the two farthest ends of the chain to prevent signal reflection and interference. This is achieved by termination switches on the communication board of the two inverters located at both ends of the chain.

IMPORTANT NOTE



Make sure the CAN Switch (see item 9 in *Figure 30*) is set to the ON position on the first and last inverters on the CAN bus.

The inverter is equipped with two glands, designated for routing the communication cables in and out of the inverter. After connecting communication cables, verify that all unused openings remain sealed.

Figure 34 shows a string of SolarEdge TerraMax Inverters linked to a CAN or RS-485 communication network.

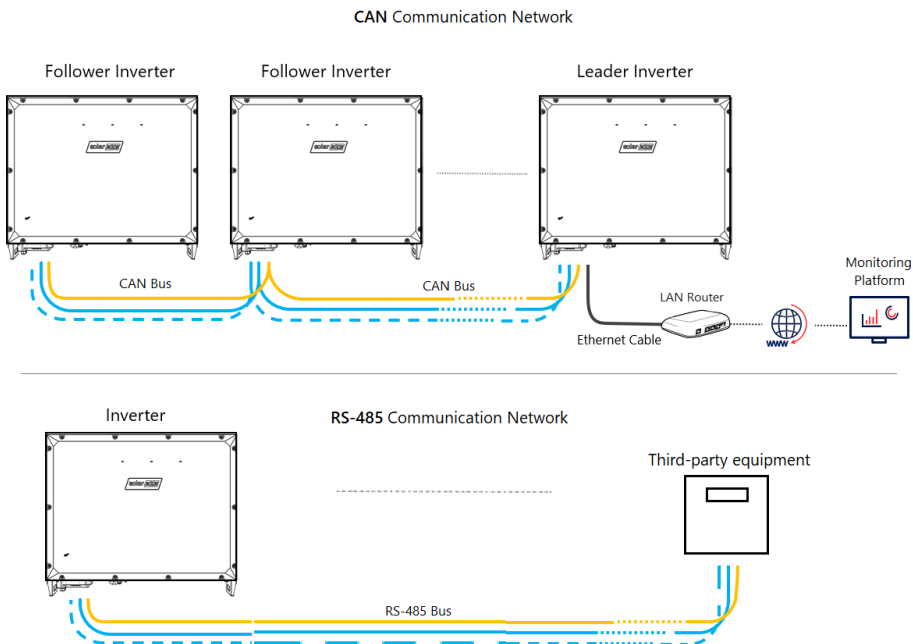

Figure 34 String of SolarEdge TerraMax Inverters linked by a CAN or RS-485 communication network

Figure 35 shows the communication compartment of the inverter.

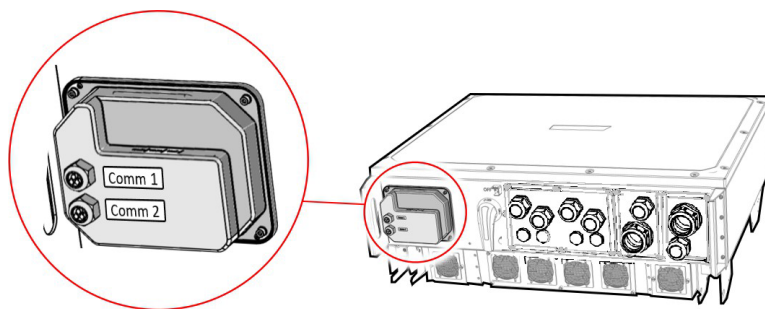

Figure 35 Figure 29: Communication compartment of the inverter

Connecting the CAN / RS-485 Communication Between Inverters / RS-485 Between Inverter and Third Party Device

Cable Requirements

- CAT5e or CAT6 cable type
- Shielded cable
- Twisted pair wires
- Conductor cross-section: 0.2 mm² to 1 mm²
- External cable diameter 2.5 to 5 mm
- Maximum CAN cable length between all connected inverters: 750 m
- Total RS-485 cable length per string: 1000 m
- 1000 V insulated
- UV-resistant for outdoor use

→ To connect the communication cables to the inverters:

1. Turn OFF the ON/OFF/P switch of the inverter.
2. Turn OFF the DC Disconnect switch of the inverter.
3. Disconnect the AC from the inverter by turning OFF the circuit breakers on the distribution panel and wait 5 minutes to allow the capacitors inside the Inverter to discharge.
4. Release the four Allen screws (1) of the communication compartment cover (2) and remove the cover (See Figure 36).

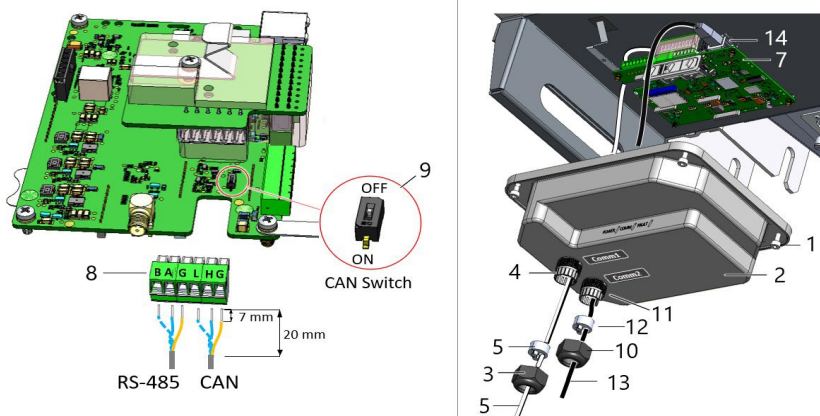

Figure 36 Connecting the communication cables

CAUTION!

When removing the cover, make sure not to damage internal components. SolarEdge will not be held responsible for any components damaged as a result of incautious cover removal.

5. Loosen the nut (3) of the Comm 1 gland (4) and remove the rubber seal (5).
6. Route the communication cable (6) via one of the openings in the rubber seal, through the gland, and the communication compartment cover (2).
7. Pull down to remove the communication board (7) from the enclosure.
8. Strip about 20 mm from the protection layer of the communication cable and expose 7 mm of conductor from each wire.
9. Secure the wires to the terminal screws of the connector (8) and plug the connector to the communication board (7). Connect the other end of the cable to the same terminals of the next inverter.
10. Terminate the first and last inverters on the communication bus by moving the CAN Switch (9) to ON. All other inverters on the bus must be switched to OFF. Make sure the resistance between H and L is 120Ω .
11. Install the communication board (7) back onto the enclosure.
12. Place the communication compartment cover (2) and secure the four Allen screws (1) to a torque of $3.9\text{ N}\cdot\text{m}$ (see *Figure 30*).
13. Place the rubber seal (4) inside the gland nut (3) of the Comm1 gland (13) and fasten the nut to a torque of $5.5\text{ N}\cdot\text{m}$.

Connecting the LAN Communication Between the LAN Router and the Leader Inverter

Ethernet Cable Requirements

- CAT5e or CAT6 cable type
- Shielded cable
- RJ45 connector
- UV-resistant for outdoor use
- Maximum cable length: 100 m

NOTE



If an Ethernet cable longer than 10 m must be used in areas where there is a risk of induced Voltage surges by lightning, it is recommended to use external surge protection devices. For details, refer to:

http://www.solaredge.com/files/pdfs/lightning_surge_protection.pdf

CAT6 or CAT5e cables have eight wires (four twisted pairs), as shown in the pin layout of the Ethernet connector in Figure 37. Wire colors may differ from one cable to another.

You can use either wiring standard, as long as both sides of the cable have the same pin-out and color-coding.

RJ45 Pin #	Wire Color ⁽¹⁾		10Base-T Signal
	T568B	T568A	100Base-TX Signal
1	White/Orange	White/Green	Transmit+
2	Orange	Green	Transmit-
3	White/Green	White/Orange	Receive+
4	Blue	Blue	Reserved
5	White/Blue	White/Blue	Reserved
6	Green	Orange	Received-
7	White/Brown	White/Brown	Reserved
8	Brown	Brown	Reserved

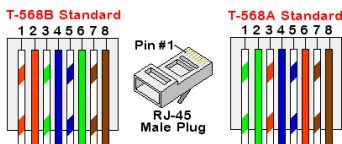

Figure 37 Ethernet connector - pin layout

⁽¹⁾The connection does not support RX/TX polarity change. Supporting crossover Ethernet cables depends on the switch capabilities.

→ To connect a LAN cable between the Leader inverter and an internet router:

1. Loosen the nut (10) of the Comm2 gland (11) and remove the rubber seal (12) from within (see *Figure 30*).
2. Route the Ethernet cable (13) through one of the openings in the rubber seal and through the gland into the enclosure.
3. Connect the CAT5e/CAT6 cable to the RJ45 connector.
4. Plug the Ethernet cable (13) into the LAN port (14).
5. Attach the communication board (7) to the enclosure.
6. Insert the rubber seal (12) into the Comm2 gland (11) and tighten the nut to 5.5 N*m.
7. Place the communication compartment cover (2) and secure the four Allen screws (1) to a torque of 3.9 N*m.

LAN Configuration

The inverter automatically establishes communication with the Monitoring Platform as it is configured to the LAN by default.

NOTE

If your network has a firewall, you may need to configure it to enable the connection to the following address:



- Destination Address: **prodssl.solaredge.com**
- Modbus TCP Port: **443** (for incoming and outgoing data)
- LAN can also be configured manually after commissioning the inverter. From the **Commissioning** screen, tap **Site Communication**. Select **Configure Ethernet** to configure the connection.

Selecting a Residual Current Device (RCD)

SolarEdge TerraMax inverters incorporate a certified internal RCD (Residual Current Device) to protect against possible electrocution in case of a malfunction of the PV array, cables, or inverter (DC). The inverter includes insulation and residual current monitoring according to IEC 62109-2 cl 4.8 to protect the DC side.

As the TerraMax system is defined as "Systems located in closed electrical operating areas," the protection against shock hazard on the PV array or detection of sudden changes in residual current is not required. The TerraMax inverter indicates a continuous residual current. According to IEC 62109-2, the inverter shall disconnect within 0.3s and indicate a fault if the continuous residual current exceeds a maximum of 10 mA per kVA of rated continuous output power.

Chapter 5: Activating, Commissioning, and Configuring the System

After the solar system is installed, it is important to activate and commission the solar system. Activation and commissioning of the system is performed using the inverter SetApp mobile application.

During the activation and commissioning, the inverter discovers and communicates with all connected components in the solar system, such as optimizers, peripheral communication devices, and other linked inverters. When commissioning is performed, the user is required to set the grid parameters and backup Voltage information (if used).

Before starting the activation and commissioning, verify all the communication hardware is properly connected.

Before arriving at the site, download the SolarEdge SetApp application to your mobile device from the Apple App Store or Google Play.

Before activation and commissioning, download the SetApp application from:



For downloading SetApp, Internet connection, one-time registration and logging are required. No registration is required for using SetApp.

IMPORTANT NOTE!



It is possible to perform DC commissioning on the inverters before completing the AC connection to the electrical grid. DC commissioning, also referred to as "commissioning from the sun", is performed in daylight using SolarEdge SetApp mobile application.

Activating the Installation

During system activation, a Wi-Fi connection is created between the mobile device and the inverter, and the system firmware is upgraded.

Before activation

- Download, register (first time only), and log in to SetApp on your mobile device. Verify that the application is updated with the latest version.
- If applicable, turn on all devices (battery, Energy Meter) connected to the inverter, so that the devices may be auto-detected.

→ To activate the inverter:

1. Turn on the AC circuit breaker on the main distribution panel.
2. Turn on the DC Disconnect Switch.
3. Open SetApp and follow the on-screen instructions (scan the inverter barcode; move the ON/OFF/P switch to P position for 2 seconds and release).
SetApp creates a Wi-Fi connection, upgrades the inverter firmware, activates the inverter, and performs pairing.
4. When the activation is completed, tap **Continue**.
5. Once pairing is completed, **Pairing Completed** will be displayed on the top banner of the SetApp Commissioning screen. Perform the following:
 - Tap and set **Country & Grid**.
 - Tap and set any other configuration parameters as required.
6. From the Commissioning screen, tap **Central Commissioning** for follower inverters detection, pairing, and central firmware upgrade and activation for all followers at once.

Commissioning and Configuring the Installation

This section describes how to use the SetApp menus for commissioning and configuring the inverter settings.

Menus may vary in your application depending on your system type.

→ To access the Commissioning screen:

Do one of the following:

- During first-time installation, upon activation completion, tap **Continue** to access the commissioning screen. To start central commissioning, tap it on the menu and follow the on-screen instructions.
- If the inverter has already been activated and commissioned:

- If not already ON - turn ON the inverter by turning ON the circuit breaker on the main distribution panel.
- Open SetApp and follow the on-screen instructions (scan the inverter QR code, move the ON/OFF/P switch to P position for 2 seconds, and release).
The mobile device creates a Wi-Fi connection with the inverter and displays the main Commissioning screen.

Setting Country and Grid

The inverter must be configured to the proper settings in order to ensure that it complies with the country's grid code and functions. Unless these settings are selected, the inverter will not start production.

1. From the **Commissioning** screen, select **Country & Grid**.
2. From the **Country & Grid** drop-down list, select the required option and tap **Set Country & Grid**.
3. If relevant, from the **Language** drop-down list, select your language and tap **Set Language**.
4. To save the information to a read-only file, tap the **PDF** icon (iOS) or the **JPEG** icon (Android) at the bottom of the screen.

Pairing

Once all connections are made, all the Power Optimizers must be paired with the inverter. This section describes how to assign the Power Optimizers to the inverter. The pairing process takes place during the first activation of the inverter. The pairing

The process is automatically triggered during the commissioning process.

In some cases, where Power Optimizers are replaced, a proactive pairing process is required.

→ To activate the proactive pairing process:

1. From the **Commissioning** menu, select **Pairing**.
2. Tap **Start Pairing** and wait for pairing to complete.
3. When **Pairing Complete** is displayed, the system startup process begins:
Since the inverter is ON, the Power Optimizers start producing power, and the inverter starts converting AC.

WARNING!



When you turn ON the ON/OFF/P switch, the DC cables carry a high voltage, and the Power Optimizers no longer output a safe output.

When the inverter starts converting power after the initial connection to the AC, the inverter enters Wake-up mode until its working voltage is reached. This mode is indicated by the flickering green inverter LED.

When the working voltage is reached, the inverter enters Production mode and produces power. The steadily lit green inverter LED indicates this mode.

4. Tap **OK** to return to the **Commissioning** menu.

Communication

Communication settings can be configured only after communication connections are complete.

From the Commissioning menu, select **Monitoring Communication > Auto Select**. SetApp will automatically detect your connection method. Follow the on-screen instructions to complete the configuration and establish communication with the monitoring platform.

From the Commissioning menu, Select **Site Communication** to configure communication between multiple SolarEdge devices or external non-SolarEdge devices, such as batteries or data loggers.

For more information on the Monitoring Platform, refer to the C&I One User Guide available on the SolarEdge website at:

https://utility.solaredge.com/hub/ci_one_user_guide.pdf

Power Control

Power control options are detailed in the Power *Control Application Note*, available on the SolarEdge website at: https://knowledge-center.solaredge.com/sites/kc/files/application_note_power_control_configuration.pdf

Verifying Proper Activation and Commissioning

1. Select **Information** and verify that the correct firmware versions are installed on each inverter. Firmware versions of the inverter can be read using the SetApp application
2. Select **Status** and verify that the inverter is operating. Make sure that **S_OK** is displayed under the **Server Comm** section.
3. Verify that additional configurations were properly set by viewing the relevant Status screens.
4. Verify that the green inverter LED is steadily lit.

Your SolarEdge power harvesting system is now operational.

Central Commissioning

After commissioning an inverter and defining the inverter as a Leader, a central commissioning process can be done.

Central commissioning enables the configuration settings of the Leader inverter to be applied at once to all Follower inverters in a significantly short time and with fewer configuration errors.

To start the central commissioning process, from the SetApp **Commissioning** screen, select **Central Commissioning** and follow the on-screen instructions.

Central commissioning is activated based on the on-site communication performance. In some cases, SetApp might guide you to commission each inverter individually.

DC Commissioning

DC commissioning enables commissioning the inverter before connecting it to the grid.

→ To perform DC commissioning:

1. Turn OFF the AC circuit breaker on the main distribution panel.
2. Verify that the DC Disconnect Switch of all inverters is in the ON position. The green and blue LED indication lights should alternate, indicating pre-commissioning.
3. Run SetApp and follow the on-screen instructions to scan the inverter barcode, move the ON/OFF/P switch to the P position for 2 seconds, and release. SetApp creates a Wi-Fi connection, upgrades the inverter firmware, activates the inverter, and performs pairing. During the process, "DC Commissioning" will appear on the top banner of the screen.

Reporting and Monitoring Installation Data

Monitoring the site requires connecting the inverter to the monitoring platform, using any of the wired or wireless options available from SolarEdge.

The Monitoring Platform

The monitoring platform provides enhanced PV performance monitoring and inverter yield assurance through immediate fault detection and alerts at the module, PV array, and system level.

Using the platform, you can:

- View the latest performance of specific components.
- Find under-performing components, such as modules, by comparing their performance to that of other components of the same type.
- Pinpoint the location of alerted components using the physical layout.

The monitoring platform enables accessing site information, including up-to-date information viewed in a physical or logical view:

- **Logical Layout:** Shows a schematic tree layout of the components in the system, such as inverters, Power Optimizers, PV arrays, modules, meters, and sensors, as well as their electrical connectivity. This view enables you to see which modules are connected in each PV array, which PV arrays are connected to each inverter, and so on.
- **Physical Layout:** Provides a bird's eye view of the actual placement of modules in the site and allows pinpointing issues to the exact location of each module on a virtual site map.

If you do not report the mapping of the installed Power Optimizers, the monitoring platform will show the logical layout, indicating which Power Optimizers are connected to which inverter, but will not show PV strings or the physical location of Power Optimizers.

The monitoring platform includes a built-in help system that guides you through the monitoring functionality.

For more information, refer to <https://www.solaredge.com/products/pv-monitoring#/>.

Creating Logical and Physical Layout using Installation Information

To display a logical layout, insert the inverter in the new site created in the monitoring platform. When the communication between the inverter and the monitoring server is established, the logical layout is displayed.

To display a physical layout, you need to map the locations of the installed power optimizers. To map the locations, use one of the methods described in the next sections.

Designer

Designer recommends inverter and Power Optimizer selection per site size and enables report generation. You can create a project in Designer and export the site design with the PV array layout to the monitoring platform.

For more information, refer to <https://www.solaredge.com/products/installer-tools/designer#/>.

Physical Layout Editor

1. If you are a registered installer, access the monitoring platform site creation page at <https://monitoring.solaredge.com/solaredge-web/p/home#createSites>.
If you have not yet signed up, go to <https://monitoring.solaredge.com/solaredge-web/p/createSelfNewInstaller>.
2. Fill out all the required information in the screen, which includes information about your installation, as well as details about its logical and physical mapping.

Appendix A: Errors and Troubleshooting

This chapter describes how to troubleshoot general system problems. For further assistance, contact SolarEdge Support.

Identifying Errors

Errors may be indicated in various system interfaces: On the inverter's bottom panel, a red LED indicates an error. In the monitoring platform and SetApp, errors are displayed with codes.

For more information on the codes displayed in SetApp and alerts displayed in the monitoring platform, refer to <https://knowledge-center.solaredge.com/sites/kc/files/se-troubleshooting-terramax-inverter-alerts-application-note.pdf>. This document describes the errors and alerts that appear in SetApp, the Monitoring Platform, and the way of troubleshooting them. To identify error types, see below.

→ To identify the error type using the inverter LEDs:

1. Move the ON/OFF/P switch to **P** position for **2 seconds** and release it.
2. Observe the LED lights and use the following table to identify the error type.

For more information, refer to: <https://www.solaredge.com/leds>

Error Type	Inverter LED Color and State		
	Green	Blue	Red
Isolation or RCD problem	OFF	OFF	Blinking
Grid error	ON	OFF	OFF
High temperature	Blinking	OFF	OFF
Pairing failed	OFF	ON	OFF
Other issue	OFF	Blinking	OFF

→ To identify the error type using the monitoring platform:

1. Open the site dashboard and click the **Layout** icon.
2. Right-click the inverter and select **Info** from the menu. The inverter details window is displayed.
3. Click the **Errors** tab. The list is displayed.

Power Optimizer Troubleshooting

Malfunction	Possible Cause and Corrective Action
Pairing failed	<p>Power Optimizers are shaded.</p> <p>Retry pairing (during sunlight). Make sure that the ON/OFF/P switch of the inverter is ON and that S_OK appears in the Status screen of the SetApp mobile application.</p>
PV string Voltage is 0V	<p>Power Optimizer (s) output is disconnected.</p> <p>Connect all Power Optimizer outputs.</p>
PV string voltage is not 0V but lower than the number of Power Optimizers	<p>Power Optimizer(s) not connected in the PV string.</p> <p>Connect all Power Optimizers.</p>
	<p>Panel(s) not connected properly to Power Optimizer inputs (not applicable to smart modules).</p> <p>Connect the modules to the Power Optimizer inputs.</p>
	<p>PV string reverse polarity.</p> <p>Check PV string polarity using a voltmeter and correct if needed.</p>
PV string Voltage is higher than the number of Power Optimizers	<p>Extra Power Optimizer(s) connected in the PV string (not applicable to smart modules).</p> <p>Check if an extra Power Optimizer is connected in the PV string. If not, proceed to the next solution.</p>
	<p>A module is connected directly to the PV string, without a Power Optimizer (not applicable to smart modules).</p> <p>Verify that only Power Optimizers are connected in the PV string and that no module outputs are connected without a Power Optimizer. If the problem persists, proceed to the next step.</p>

Malfunction	Possible Cause and Corrective Action
<p>WARNING!</p> <p> If the measured voltage is too high, the installation may not have a safe low voltage. PROCEED WITH CARE! A deviation of $\pm 1\%$ per PV string is reasonable.</p>	<p>Power Optimizer(s) malfunction.</p> <ol style="list-style-type: none"> 1. Disconnect the wires connecting the Power Optimizers in the PV string. 2. Measure the output voltage of each Power Optimizer to locate the Power Optimizer that does not output 1V safety Voltage. If a malfunctioning Power Optimizer is located, check its connections, polarity, module, and Voltage. 3. Contact SolarEdge Support. Do not continue before finding the problem and replacing the malfunctioning Power Optimizer. If a malfunction cannot be bypassed or resolved, skip the malfunctioning Power Optimizer, thus connecting a shorter PV string.

Troubleshooting Communication

Troubleshooting Ethernet (LAN) Communication

The possible errors and their troubleshooting are detailed in the following table:

Error Message	Possible Cause and Troubleshooting
LAN cable disconnected	Physical connection fault. Check the cable pin-out assignment and cable connection.
No DHCP Configure Static IP or set to DHCP	IP settings issue. Check the router and configuration. Consult your network IT.
Gateway not responding	Ping to the router failed. Check the physical connection to the switch/ router. Check that the link LED at the router /switch is lit (indicating phy-link). If OK - contact your network IT, otherwise replace the cable or change it from a cross to a straight connection.

No Internet connection	<p>Ping to google.com failed. Connect a laptop and check for an internet connection. If internet access is unavailable, contact your IT admin or your internet provider.</p> <p>For Wi-Fi networks, ensure that the username and password match those defined by the internet provider on the AP/router.</p>
------------------------	--------------------------------------------------------------------------------------------------------------------------------------------------------------------------------------------------------------------------------------------------------------------------------------------------------------

Troubleshooting CAN Bus Communication

If, after follower detection, the number of followers displayed for the leader under CAN menu > **Followers** is lower than the actual number of followers, refer to the following application note to identify missing followers and troubleshoot connectivity problems: <https://knowledge-center.solaredge.com/sites/kc/files/se-troubleshooting-undetected-can-bus-follower-devices-application-note.pdf>

Additional Troubleshooting

1. Check that the modem or hub/router is functioning properly.
2. Check that the connection to the internal connector on the communication board is properly done.
3. Check that the selected communication option is properly configured.
4. Use a method independent of the SolarEdge device to check whether the network and modem are operating properly. For example, connect a laptop to the Ethernet router and connect to the Internet.
5. Check whether a firewall or another type of network filter is blocking communication.

Isolation Fault

In photovoltaic systems with a transformer-less inverter, the DC is isolated from ground. PV modules with defective isolation, unshielded wires, defective power optimizers, or a faulty inverter can cause a leakage of DC current to the ground (PE - protective

earth). Such a fault is also called an isolation fault or ground fault. To identify and locate an isolation fault in a PV system, refer to:

<https://knowledge-center.solaredge.com/sites/kc/files/se-terramax-inverter-isolation-fault-troubleshooting-application-note.pdf>

Appendix B: Maintenance

This appendix describes how to perform preventive maintenance on the site. By performing these preventive maintenance tasks, you can help keep the site functioning properly and avoid potential problems, track and record the maintenance procedures.

CAUTION!



Neglecting required maintenance on the inverter can lead to overheating and power loss due to derating. In some cases, lack of maintenance may also damage the inverter itself. To prevent these issues, be sure to perform all maintenance procedures detailed in this appendix.

Routine Maintenance of the System

Once every six months, perform a maintenance inspection of the site to ensure its proper and efficient functioning and prolong its lifespan.

NOTE



The frequency of maintenance inspections may vary according to the environmental conditions. A dusty environment may require more frequent inspections.

Inspection Type	Description	Pass	Fail
Ongoing site-related issues	Review any outstanding issues or alarms from the monitoring system. Check grid status, circuit isolation, and other factors that could be impacting the system.		
Visual inverter surrounding	Look for any signs of damage, corrosion, or overheating around the inverter. Document any concerning issues.		
Cables, conduit, and glands	Visually inspect electrical cables, conduits, and glands for fraying, cracking, loose connections, or other damage.		
Inverter fans	Visually inspect fans for dust buildup. Clean fan blades and vents if excessive debris is present.		
Signs of overheating	Use an infrared camera to check for hot spots on connectors, terminals, busbars, and other components, indicating overheating issues.		

Visual Inspections

By performing these inspection steps, you can help ensure that your inverter is installed safely:

1. Check the mounting of the inverter: Check that the mounting brackets of the inverter are secured to the metal fixture and not showing signs of wear, damage or corrosion. Make sure that the inverter is firmly installed.
2. Inspect the physical condition: Inspect the physical condition of the inverter enclosure. Check for cracks, dents, and other physical damage. Ensure that all screws securing the front panel are in place.
3. Check the ventilation: Check that the cooling fans, at the bottom of the inverter, operate and that air can freely flow around the inverter.
4. Check the conduit connections: Inspect the physical condition of the conduits. Ensure that conduits are secured properly to the inverter.
5. Check the wiring glands: Check that the unused openings/glands at the bottom of the Inverter are sealed.
6. Check the wiring: Check that cables and wires are not damaged. If cables are disconnected, immediately power off the inverter.

Ground Connection

The following process should only be done by a qualified electrician or someone with the proper training and equipment to avoid electrical hazards.

Use a continuity tester to check the continuity between the metal fixture of the inverter, the inverter's enclosure, the metal conduits, and the grid earth. The tester should indicate a continuous circuit.

Fan Maintenance

Each inverter has cooling fans that can be accessed from the bottom panel of the enclosure. Keep the fan clean and free of dust. When needed, and at least once a year, clean the accumulated dust using a brush.

Check each fan to make sure it is functioning properly and is free of dust and debris. A dirty fan can cause the inverter to overheat, reducing its efficiency.

→ To clean the fans of the inverter:

1. Turn ON/OFF/P Switch of the inverter to OFF (0) (See Figure 38).

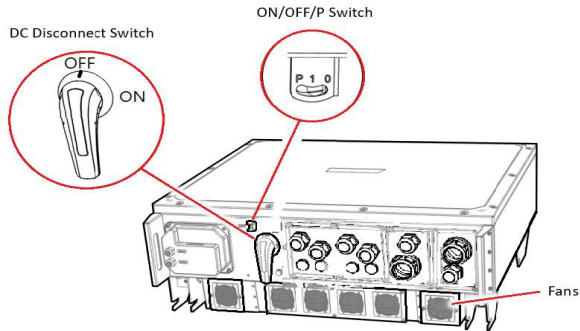

Figure 38 Removing the Fans

2. Turn OFF the DC Disconnect Switch on the bottom of the inverter.



WARNING!

Wait five minutes before opening the cover. Otherwise, there is a risk of electric shock from energy stored in the capacitors.

3. Turn OFF the AC circuit breaker on the distribution panel.
4. Clean the accumulated dust on the fan and screen using a brush.
5. Turn ON the AC circuit breaker on the distribution panel.
6. Turn ON the DC Disconnect Switch at the bottom of the inverter.
7. Turn ON(I) the ON/OFF/P Switch of the inverter.
8. Use the SetApp mobile application to connect to the inverter and follow the on-screen instructions. From the Commissioning screen, tap Status and check that Fan OK is displayed in the Status screen.

Wire Connections

→ To maintain the wire connections of the inverter:

1. Turn the ON/OFF/P Switch of the inverter to OFF (0) and wait for five minutes for the DC Voltage inside the inverter to drop to a safe value before proceeding to the next step.



WARNING!

Wait five minutes before opening the cover. Otherwise, there is a risk of electric shock from energy stored in the capacitors.

2. Turn OFF the DC Disconnect Switch on the bottom of the inverter.
3. Turn OFF the AC circuit breaker on the distribution panel.
4. Remove the front cover of the inverter.
5. Inspect the wire connections: Visually inspect all wire connections, looking for signs of damage, wear and tear, loose connections, or overheating. If you find any signs of damage, it's important to address them promptly to prevent further issues. Torque the nuts of the AC, DC, and Ground (PE) terminals as described in "Installing the Inverter" on page 33.
If you find any issues, repair or replace the wire as necessary.
6. Attach the inverter cover and secure the four screws to 3.9 N*m in a crossed pattern.
7. Turn ON the AC circuit breaker on the distribution panel.
8. Turn ON the DC Disconnect Switch on the front cover of the inverter.
9. Turn ON(I) the ON/OFF/P Switch of the inverter.

General Cleaning

Clean the inverter: Dirt and debris can accumulate on the inverter over time, which can reduce its performance. Clean the inverter regularly with a soft brush, a soft cloth, and mild detergent to keep it functioning efficiently.

Monitoring the Solar System Performance

The SolarEdge monitoring platform enables monitoring of PV strings connected to the inverter. It provides accurate information about the present and past performance of each PV module individually and the system. The platform enables the detection, pinpointing, and troubleshooting of faults, efficiently manages maintenance operations, and analyzes site profitability.

Smart algorithms continuously track the power, Voltage, and current of all PV modules and inverters, as well as a range of statistical indicators to detect performance events that require intervention or maintenance.

If you are experiencing alerts from the SolarEdge monitoring system, it may indicate an issue with the PV modules, inverter, or the monitoring system itself. Some common alerts include:

1. Panel mismatch: This alert occurs when the performance of one or more panels in the solar array does not match the expected performance. This could be due to shading, soiling, a malfunction, or other factors that are affecting the performance of the panel.

To learn more about generating a PV module mismatch report, refer to https://knowledge-center.solaredge.com/sites/kc/files/monitoring_platform_mismatch_analysis_report.pdf

2. Inverter failure: This alert occurs when the inverter, which is responsible for converting the DC power generated by the PV modules into AC power, has failed. To learn more about viewing alerts in the monitoring platform, refer to <https://knowledge-center.solaredge.com/sites/kc/files/se-alerts-in-monitoring-application-note.pdf>

Appendix C: SafeDC™

When the AC supply to the inverter is shut off (by shutting off the AC breaker at the site), or when the inverter ON/OFF/P switch is turned to OFF, the DC Voltage drops to a safe Voltage of 1V per Power Optimizer.

The SolarEdge inverters are certified for compliance with the following standards as disconnection devices for PV generators, meaning that they can replace a DC disconnect:

- IEC 60947-3:1999 + Corrigendum: 1999 + A1:2001 + Corrigendum 1:2001 + A2:2005;
- DIN EN 60947-3
- VDE 0660-107:2006-03
- IEC 60364-7-712:2002-05
- DIN VDE 0100-712:2006-06.

In compliance with these standards, follow the instructions below to disconnect the DC power:

1. Move the inverter ON/OFF/P switch to OFF (0), as shown in *Figure 33*.
2. Move the DC Disconnect Switch to the OFF position, as shown in the following image.

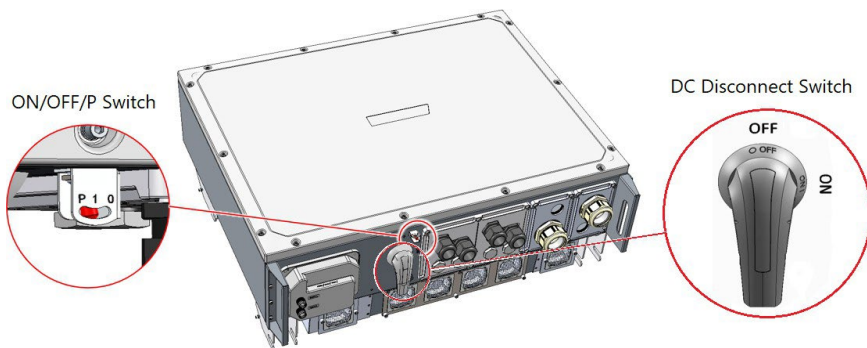

Figure 39 ON/OFF/P Switch and DC Disconnect Switch

3. Disconnect the AC from the inverter by turning OFF the circuit breakers on the distribution panel.

Appendix D: Technical Specifications

	SE300K	SE330K	Units
OUTPUT			
Rated AC Active Output Power	297,000 @ 45°C	330,000 @ 45°C	W
Maximum Apparent AC Output Power	297,000 @ 45°C	330,000 @ 45°C	VA
AC Output Voltage – Line to Line (Nominal)	690		Vac
AC Output Voltage – Line to Line (Range)	587 – 759		Vac
AC Frequency	50 ± 5%		Hz
Rated Continuous Output Current (per Phase) @Nominal Voltage	276.1		Aac
Maximum Continuous Overcurrent Protection	450		Aac
AC Output Line Connections	3W + PE		
Residual Current Detector	Yes, in accordance with IEC 62109-2		
Grid Supported	WYE: TN-C, TN-S, TN-C-S, TT, IT; Delta: IT		
Inrush Current AC (Peak/Duration)	25/80		Aac/ms
Total Harmonic Distortion	≤3		%
Protective Class	Class I		
Utility Monitoring, Islanding Protection, Configurable Power Factor, Country Configurable Thresholds	Yes		
Power Factor Range	0.2 – 1 / leading, lagging		
Overvoltage Category	III		
INPUT			
Maximum DC Power (Module STC)	594,000	660,000	W
Transformerless	Yes		
Maximum Input Voltage DC+ to DC-	1500		Vdc
Nominal DC Input Voltage DC+ to DC-	1250		Vdc
Maximum Input Current	266.7		Adc
Maximum Back-feed Current	0		Adc
Overvoltage Category	II		
Module-Level Optimization	Yes		
EFFICIENCY			
Maximum Efficiency / EU Efficiency	99.2 / 98.8		%
PROTECTION FEATURES			
DC Reverse Polarity Protection	Yes		
Ground Fault Isolation Detection	Yes, in accordance with IEC 62109-2		
AC Surge Protection	Type 2, monitored and field replaceable		
DC Surge Protection	Type 2, monitored and field replaceable		
CAN, RS485 Surge Protection	Yes		
DC Disconnect	Yes, integrated		

SE300K		SE330K ⁽⁴⁾		Units	
ADDITIONAL FEATURES					
Supported Communication Interfaces	CAN bus, RS485, Ethernet, WiFi, Cellular (optional)				
PID Protection	PID Rectifier				
Inverter Commissioning	With the SetApp mobile application using built-in Wi-Fi access point for local connection				
Pre-Commissioning	Inverter activation and validation powered by PV modules				
VAR at Night	Yes				
STANDARD COMPLIANCE					
Safety	IEC 62109, AS3100 ⁽⁵⁾				
Grid Connection Standards	EN 50549-2, C10/11, PO 12.3, AS 4777 ⁽⁵⁾ , G99 Type A and B ⁽⁵⁾ , CEI 0-16, NTS, TOR Erzeuger Type B, C, D		VDE-AR-N 4110, VDE-AR-N 4120		
EMC	IEC/EN 61000-6-2, IEC 61000-6-4, EN 55011, CISPR 11, IEC 62920				
RoHS	Yes				
GENERAL DATA					
Dimensions (W x H x D)	1090 x 914 x 416			mm / in	
Weight	163 / 359			kg / lb	
Operating Temperature Range ⁽¹⁾	-40 to +60			°C / °F	
Cooling	Fans (field replaceable)				
Noise Emission	< 72			dBa	
Protection Rating	IP66				
Mounting	Bracket provided				
Topology	Transformerless				
AC Connection ⁽²⁾	2 Glands, Cable Diameter 48 – 55mm, Terminal Lugs, Max. 300mm ² per wire, Al or Cu				
DC Connection ⁽³⁾	4 Glands, Wire Diameter 22 – 32mm, Terminal Lugs, Max. 300mm ² per wire, Al or Cu				
Average Short Circuit Current During Fault					
Inverter Model @ 690V L-L	I _p (A)	I _{nom} (A)	1 Cycle RMS (A)	3 Cycles RMS (A)	Duration (ms)
SE330K / SE300K	592	275	217	236	150

(1) For ambient temperatures above +45°C / 113°F power derating is applied. Refer to the Temperature Derating Technical Note for more details.

(2) Two AC terminals per phase are available.

(3) Up to two DC terminals (+, -) are available.

(4) Available in DACH countries that follow VDE-AR-N-4110/VDE-AR-N-4120.

(5) Certification pending.